



Capacity Building in Teaching of AR/VR (CATCH_VR)
European Commission Project# 101129191 (ERASMUS-EDU-2022-CBHE)



Digital Twin And SCADA Control System

Conducted by:

Dr. Zubair Ahmad
University of Engineering and Technology,
Peshawar



Safety Moment

Visibility Issues with Dark clothes and low light conditions with approaching winter

Statistics

- In 2017 there were 5,977 pedestrians and 783 bicyclists killed in crashes with motor vehicles in the USA
- In 2018 there were 6,227 pedestrians and 861 bicyclists killed in crashes with motor vehicles in the United States

As a Driver

- Be vigilant for passersby and cyclists
- Avoid multi-tasking and distracted driving
- Follow speed limits

For Pedestrian and Cyclist

- Consider having reflecting gear if walking or cycling
- Do not Jaywalk
- Be vigilant for approaching traffic
- Have an eye contact with drivers before crossing the road

Digital Twin And SCADA Control System

- Introduction to Digital Twin
- Digital Twin concept and component
- Basics of SCADA System
- Examples of SCADA Systems
- Subsystems of SCADA System
- Capabilities of SCADA System
- Commonly used SCADA Software
- SCADA System Design Objectives and Challenges
- Control System Documentation
- Example Projects
- DT Integration with SCADA
- DT SCADA Relationship and Data Flow
- Application
- Limitations and Challenges
- Conclusion

Digital Twin Introduction

- Digital Twins (DTs) are virtual replicas of physical assets, processes, or systems, continuously updated with real-time data for monitoring, analysis, and optimization.

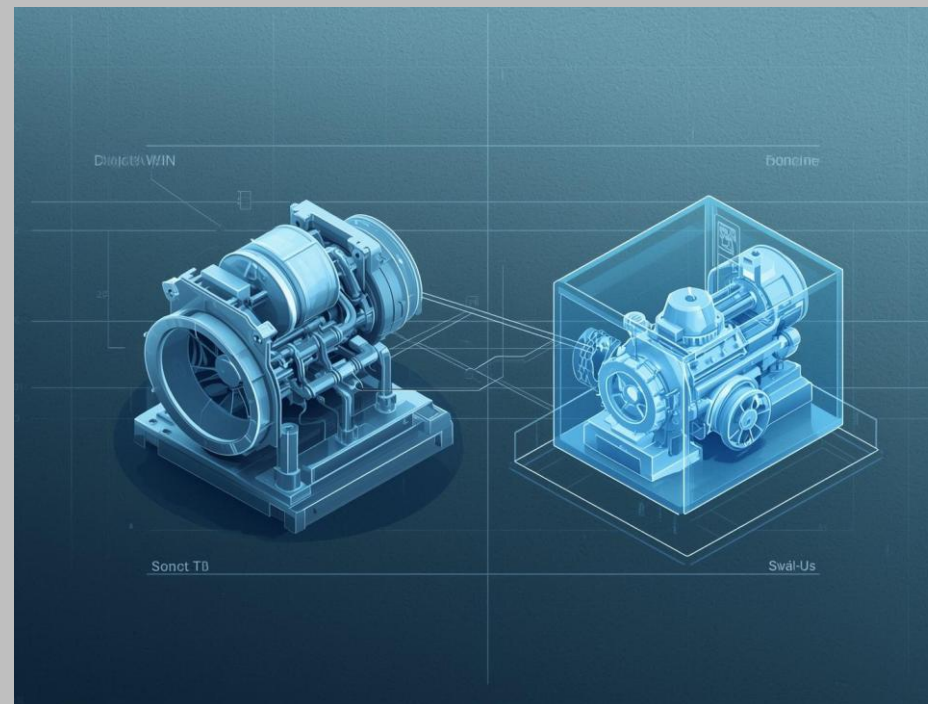

Evolution of the Digital Twin

- Originated in NASA's Apollo mission for simulation of spacecraft behavior; now central to Industry 4.0 for predictive and adaptive operations.

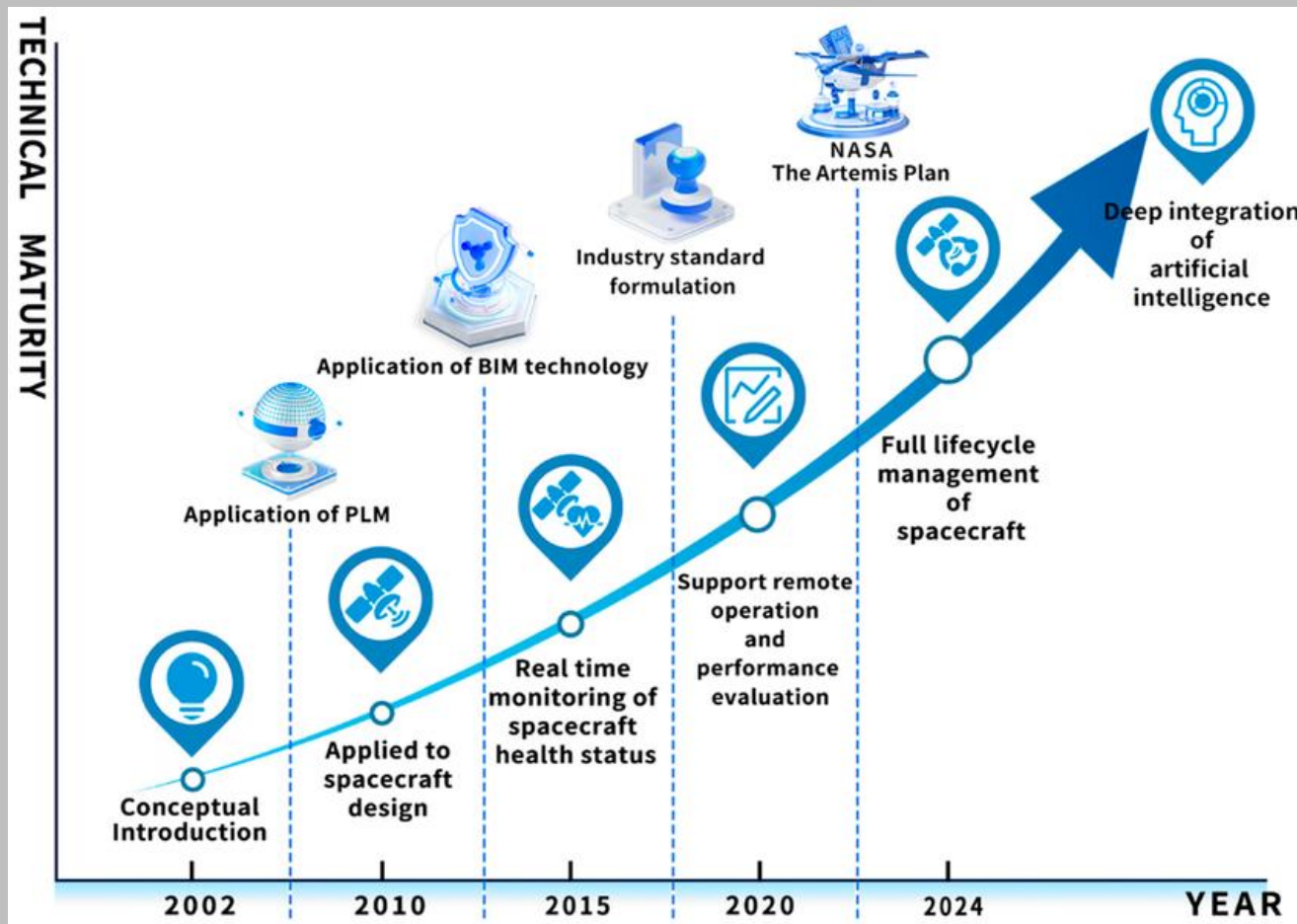

Core Concept of DT

- A DT links the physical and digital through data, creating a feedback loop for real-time decision-making and optimization.

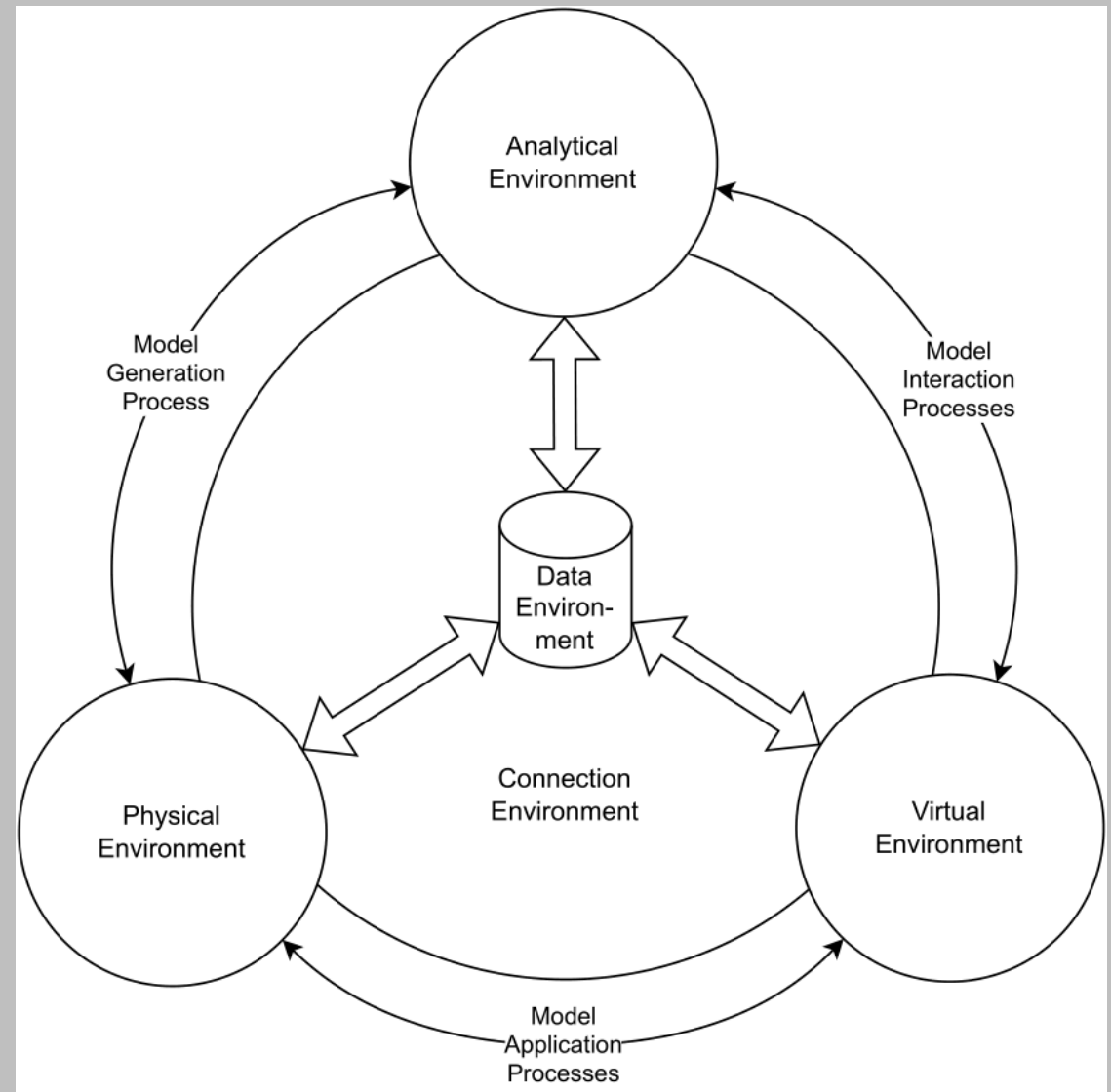

Components of a Digital Twin

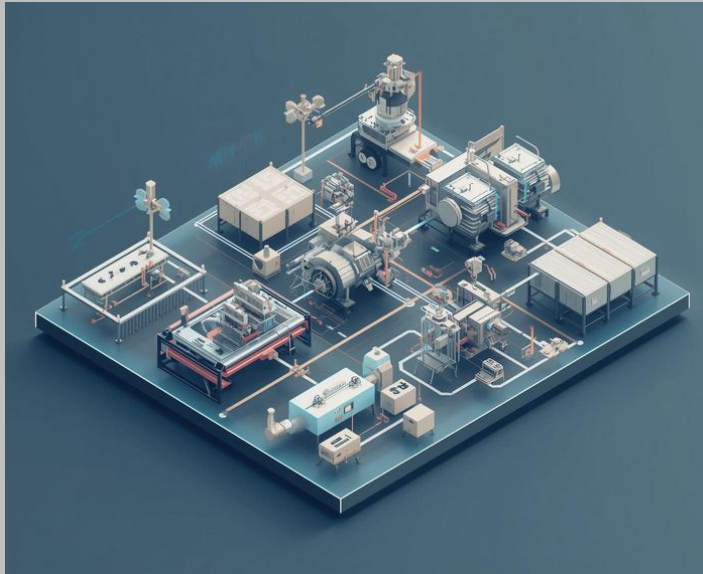

Model

A virtual representation of physical assets.



Data

Real-time information to inform decisions.



Integration

Combining physical and digital elements seamlessly.

Digital Twin Architecture

- Uses sensors, communication networks, and computational models to synchronize digital and physical spaces.

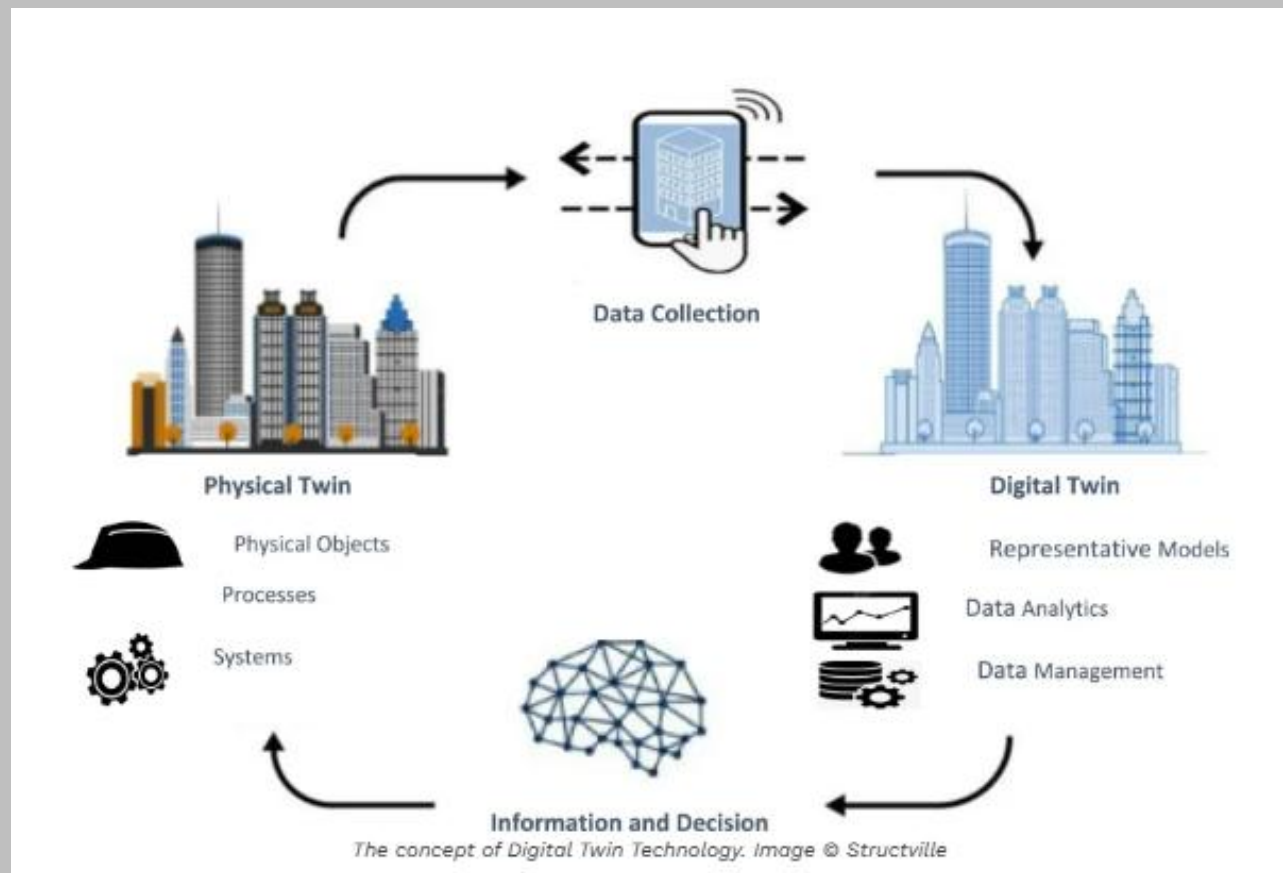

Types of Digital Twins

PRODUCT Twinning

Providing a virtual-physical connection to analyze how a product performs under various conditions and make adjustments in the virtual world to ensure that the physical product will perform exactly as planned in the field



PROCESS Twinning

Using digital twins to improve processes and workflows by allowing managers to tweak inputs and see how outputs are affected without the risk of upending existing workflow



SYSTEM or PERFORMANCE Digital Twin

Using digital twins to capture, analyze, and act on operational data, providing insights for informed decisions to maintain effective interactions among the components of the system at the system level



Benefits of Digital Twin



DT and SCADA: Data Flow Relationship

- SCADA collects data → DT analyzes, predicts, and feeds back optimized
- control parameters → SCADA executes actions.
- This section illustrates the seamless **data flow** from physical sensors to the Digital Twin, emphasizing how real-time data collection enables accurate representations of physical assets. Understanding this process is crucial for effective monitoring and decision-making in industrial automation.

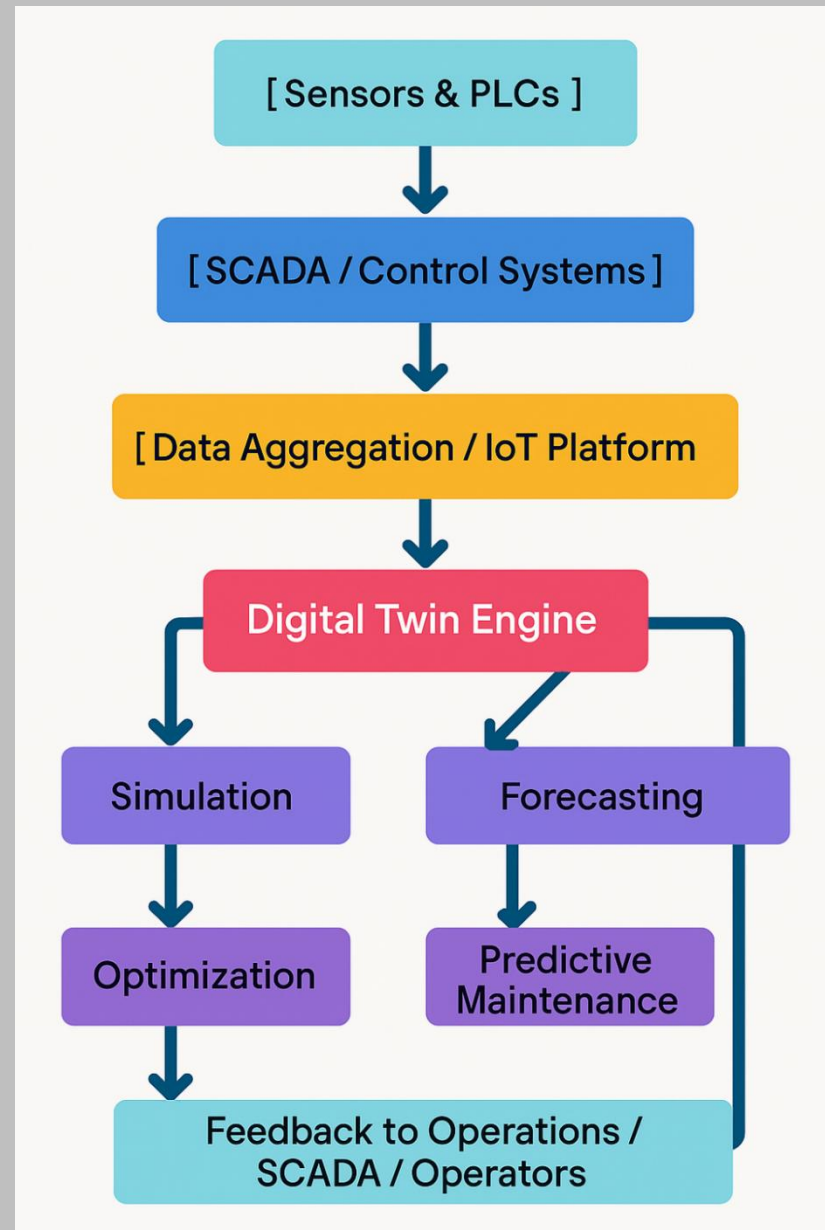

SCADA Control System

Basics of SCADA System

SCADA stands for “Supervisory Control and Data Acquisition”

It is a Real Time Industrial Process Control System

It is used to monitor and/or control automated processes from a centralized location

Automated processes controlled by SCADA system can be

- Water and Wastewater Plants
- Water Distribution systems
- ITS (Intelligent Transportation System)
- Chemical Plant Processes
- Oil Refineries
- Oil and Gas pipelines
- Cement Plants
- Electrical Generation and Transmission Equipment

SCADA Control System

Basics of SCADA System

History of SCADA System

- It is evolved from the telemetry system developed for the Space Program to measure and report information
- Its biggest challenge was lack of bandwidth
- With the advance of microprocessor technology and cheap availability of bandwidth led to more sophisticated monitoring, control and logging of automated processes, often referred as SCADA

SCADA Control System

Basics of SCADA System

Examples of SCADA System

Control Room or Operator Control Center (OCC)



SCADA Control System

Basics of SCADA System

Examples of SCADA System

Control Room or Operator Control Center (OCC)



SCADA Control System

Basics of SCADA System

Examples of SCADA System

Control Room or Operator Control Center (OCC)



SCADA Control System

Basics of SCADA System

Examples of SCADA System

Control Room or Operator Control Center (OCC)



SCADA Control System

Basics of SCADA System

Examples of SCADA System
HMI (Human Machine Interface)



SCADA Control System

Basics of SCADA System

SCADA refers to centralized system which can monitor and control one or more then one automated process from a single location.

SCADA System can monitor number of geographically scattered remote sites, each equipped with PLCs.

The PLCs at remote sites measure and control array of parameters and will communicate it to a centralized location for monitoring, control and data analysis, if needed.

SCADA Control System

Basics of SCADA System

Most Control actions at the field are performed automatically by PLC but SCADA system provides the overriding or Supervisory level intervention from the control room e.g.

- Allowing operator to remotely change the setpoints
- Enabling or Disabling Alarms from remote location
- Allowing operator to acknowledge Alarms remotely

SCADA Control System

Basics of SCADA System

SCADA System monitors the overall performance of the control system

Basic data acquisition like analog instrument readings, monitoring equipment status and alarming can be done in PLC logic in the field and can be communicated to SCADA for data logging

Acquired data from PLC can be used by the SCADA system to generate alarms and prompts in the control room

SCADA Control System

Examples of SCADA System

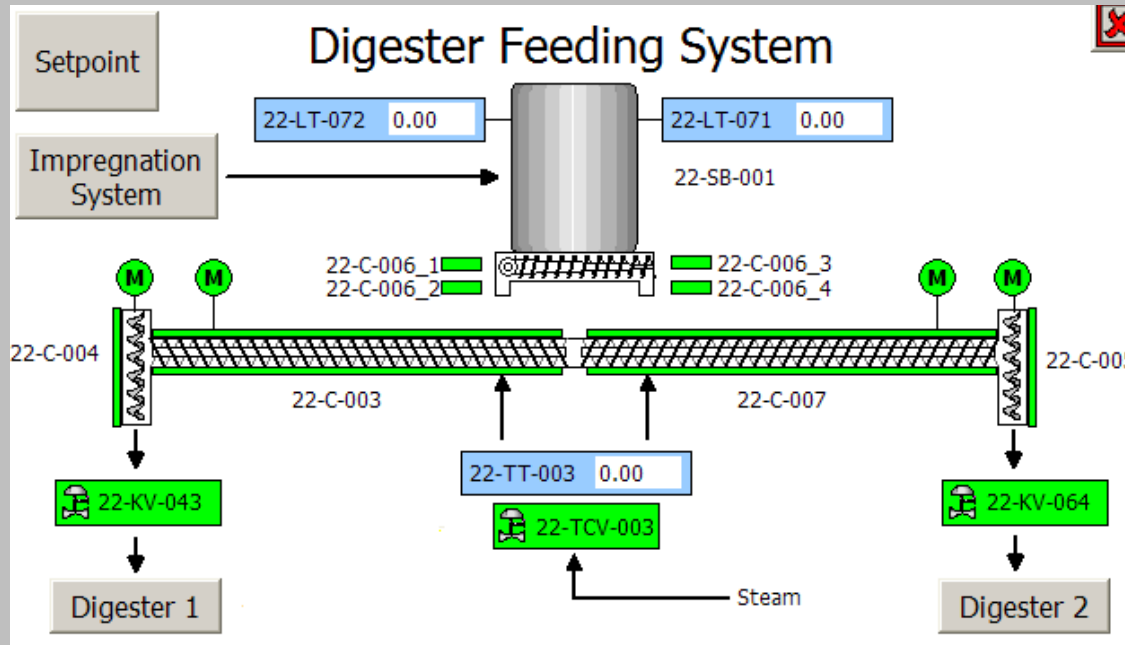

- PLC controls the running of the conveyors and opening/ closing of the actuated valves on the base of level transmitters installed at the top of tank
- Differential temperature transmitter detect the working temperature of the horizontal screw conveyors and controls the injection of steam

SCADA Control System

Examples of SCADA System

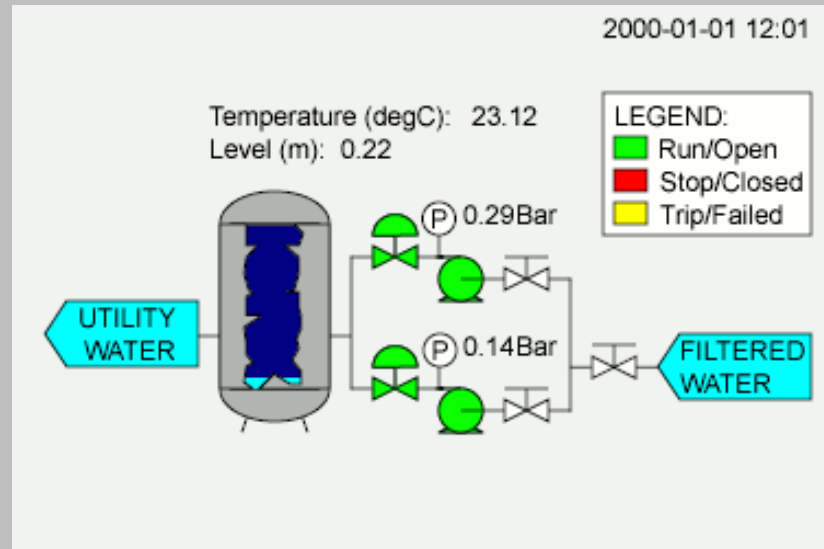

- PLC may control the start/ stop of pumps and opening/ closing of valves on the base of level in the tank
- SCADA system may allow the operator to change the setpoints for the flow, start/ stop the pumps and open/ close the valves manually, enable and acknowledge the alarms i.e. Loss of Flow or High Temperature.

SCADA Control System

Subsystems of SCADA System

- Supervisory Computer
- HMI (Human Machine Interface) Software
- Application Server
- SCADA Software
- RTU or PLC or PAC
- Communication Infrastructure

SCADA Control System

Subsystems of SCADA System

Supervisory Computer

- Supervisory Computer is also called an Operator Console
- Operator Console can be an OIT (Operator Interface Terminal) or can be a PC (Personal Computer)

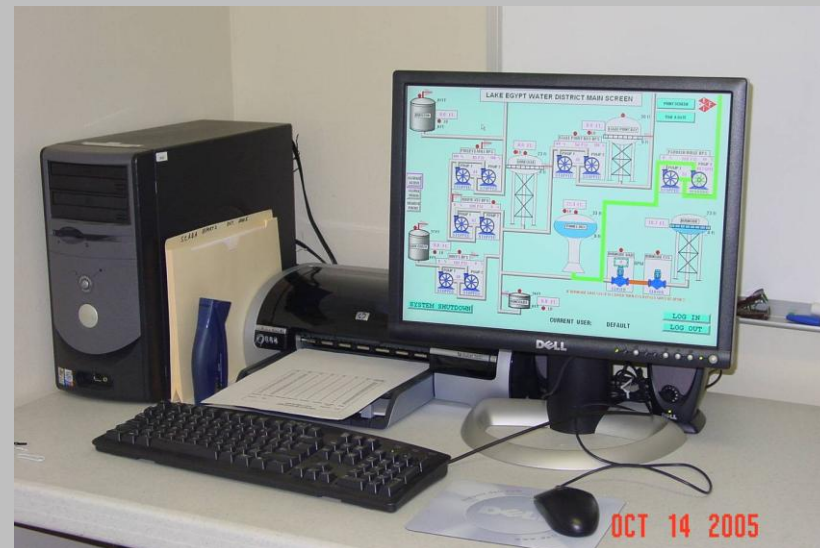

SCADA Control System

Subsystems of SCADA System

Supervisory OIT installed at the front of a Control Panel running HMI (Human Machine Interface) software

Example:



SCADA Control System

Subsystems of SCADA System

HMI (Human Machine Interface)

- It is a software application running in the operator console of SCADA system that permits operator to visualize the process.
- HMI is a mechanism which presents the live process data to human operator console and it helps the operator to monitor, log or control the process.
- It is a custom Software which provides Graphics based visualization of an Industrial Control and Monitoring System
- HMI is also called Process Visualization Software and run on supervisory computer

SCADA Control System

Subsystems of SCADA System

HMI (Human Machine Interface). Example Screen

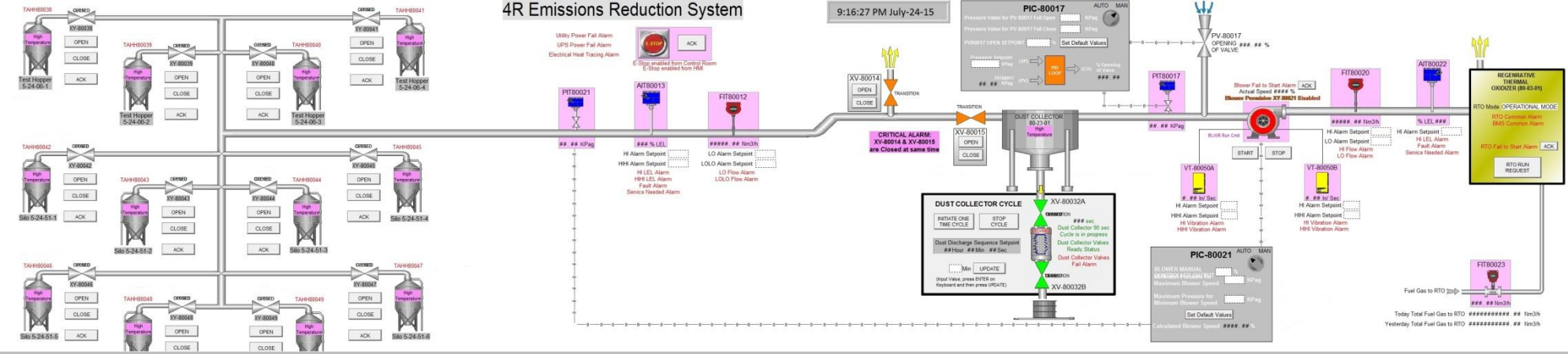

SCADA Control System

Subsystems of SCADA System

HMI (Human Machine Interface). Example Screen

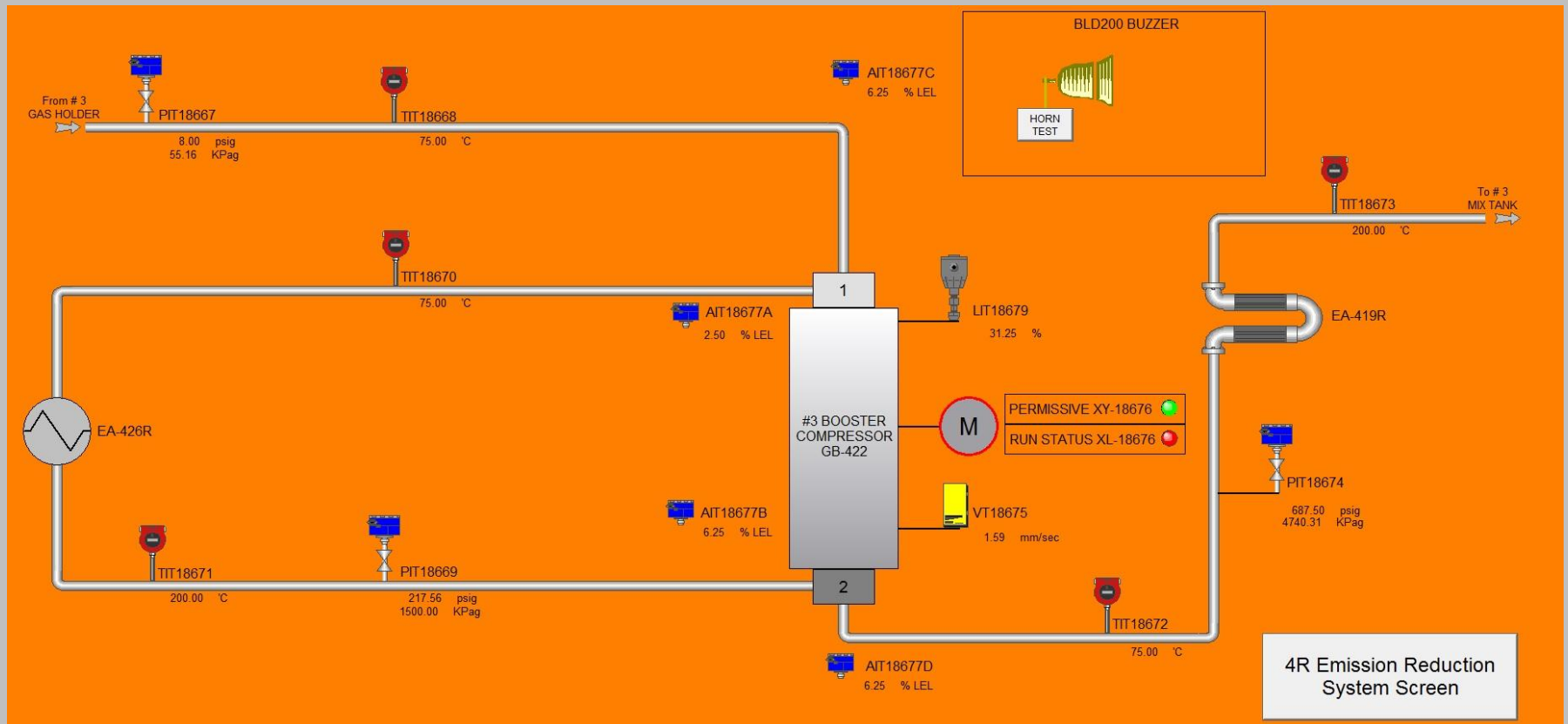

SCADA Control System

Subsystems of SCADA System

HMI (Human Machine Interface). Example Screen

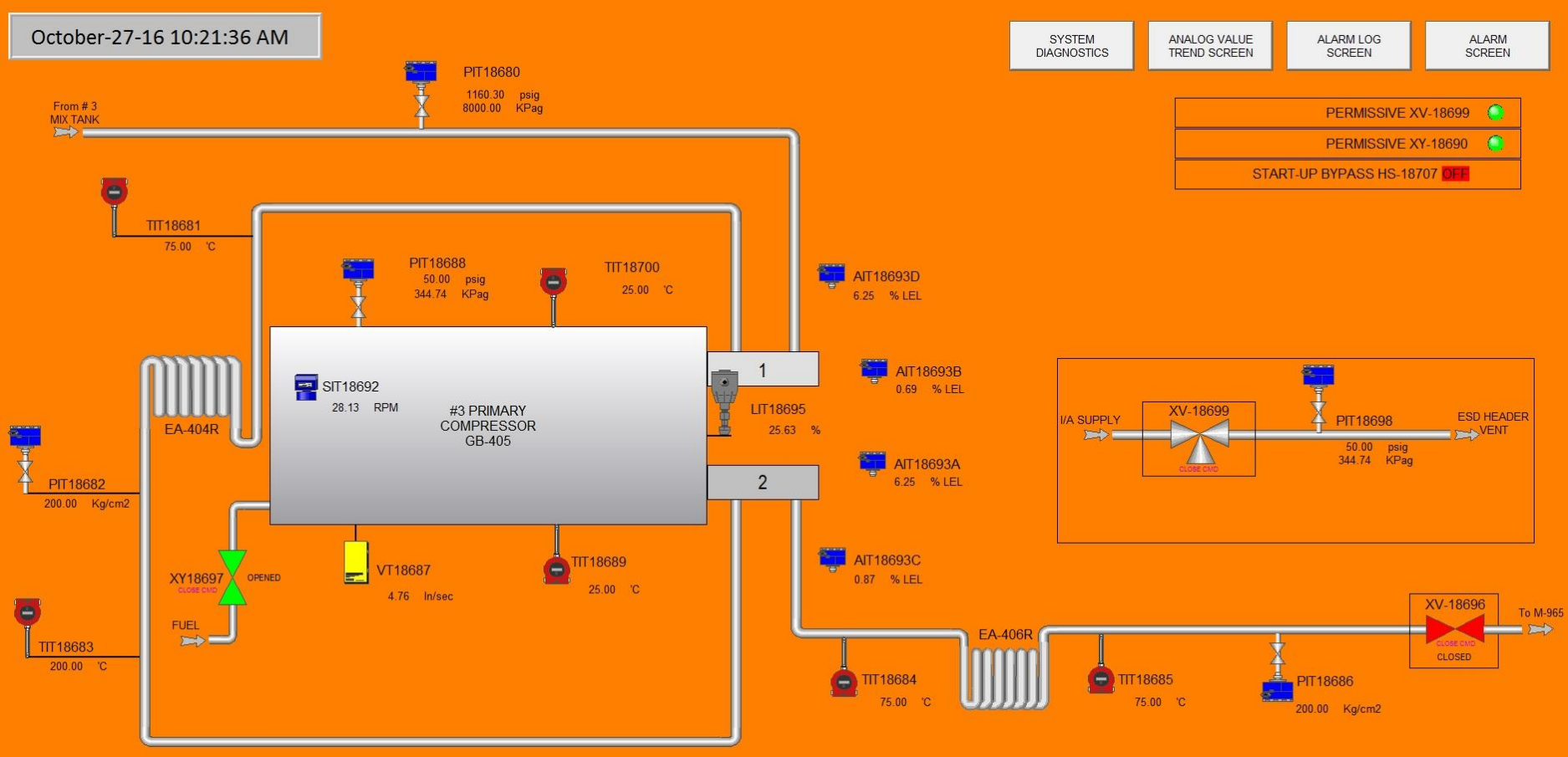

SCADA Control System

Subsystems of SCADA System

Application Server

It is computer hardware running SCADA software

It is suppose to host the software and applications that are computationally intensive and which require big memory storage capacity i.e.

- SCADA Software
- Database Management System
- Data logging
- Historical Data Trending
- Data Reporting
- Production Management Software
- Process Optimization Software
- SAS (Statistical Analysis System) Software etc

SCADA Control System

Subsystems of SCADA System

Application Server

Application servers can act as secure remote terminal server providing access for multiple users simultaneously and controlling privileges and area access.



SCADA Control System

Subsystems of SCADA System

SCADA Software

Development platform for SCADA
Application



SCADA Control System

Subsystems of SCADA System

PLC (Programmable Logic Controller)

It is a solid state control device that is programmed to automatically control an industrial process or machine.

Developed by automotive industry to reduce their change over costs of relay panels required by annual model changes

Its different variants are

- RTU (Remote Terminal Unit) and
- PAC (Programmable Automation Controller)

SCADA Control System

Subsystems of SCADA System

Communication Infrastructure

It involves transmission of data in digital form from one place to other place

There are many standards for industrial networks made by standards-making body

Industrial networks are designed for efficiently transporting certain types of industrial automation data

Industrial Networks are classified with the following titles

- Discrete Sensor Data
- Process Control fieldbus
- Control Level Network
- Information Technology Networks

SCADA Control System

Subsystems of SCADA System

Communication Infrastructure

Different Industrial Network Standards are below

- AS-I (Actuator Sensor Interface)
- CAN (Control Area Network)
- CAN Open
- DeviceNet
- SDS
- ControlNet
- EtherNet/ IP
- Foundation Fieldbus H1
- Foundation Fieldbus HSE
- LonWorks
- Modbus
- Profibus-DP
- Profibus-PA
- Profinet
- WorldFIP
- Interbus

SCADA Control System

Subsystems of SCADA System

Communication Infrastructure

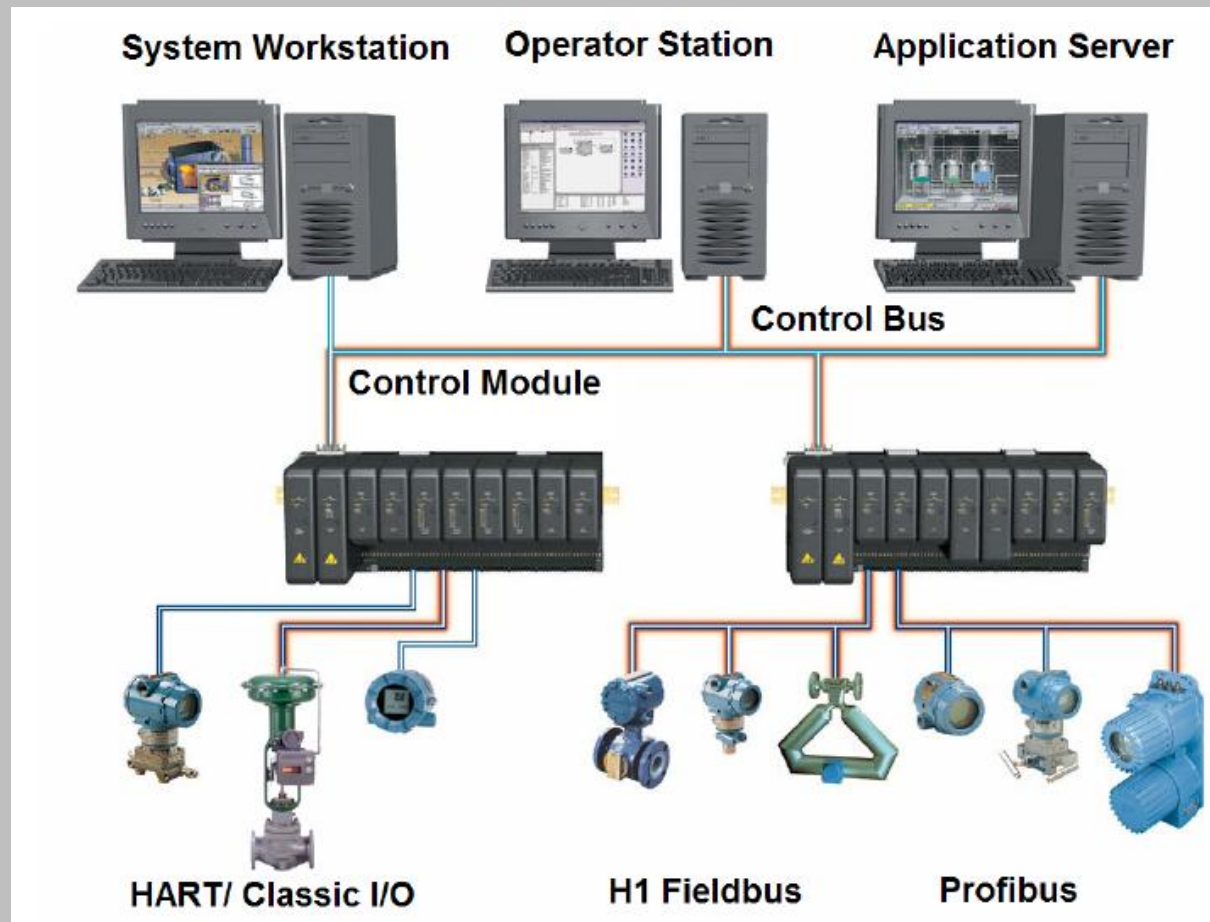

SCADA Control System

Network Diagrams of SCADA System

Example

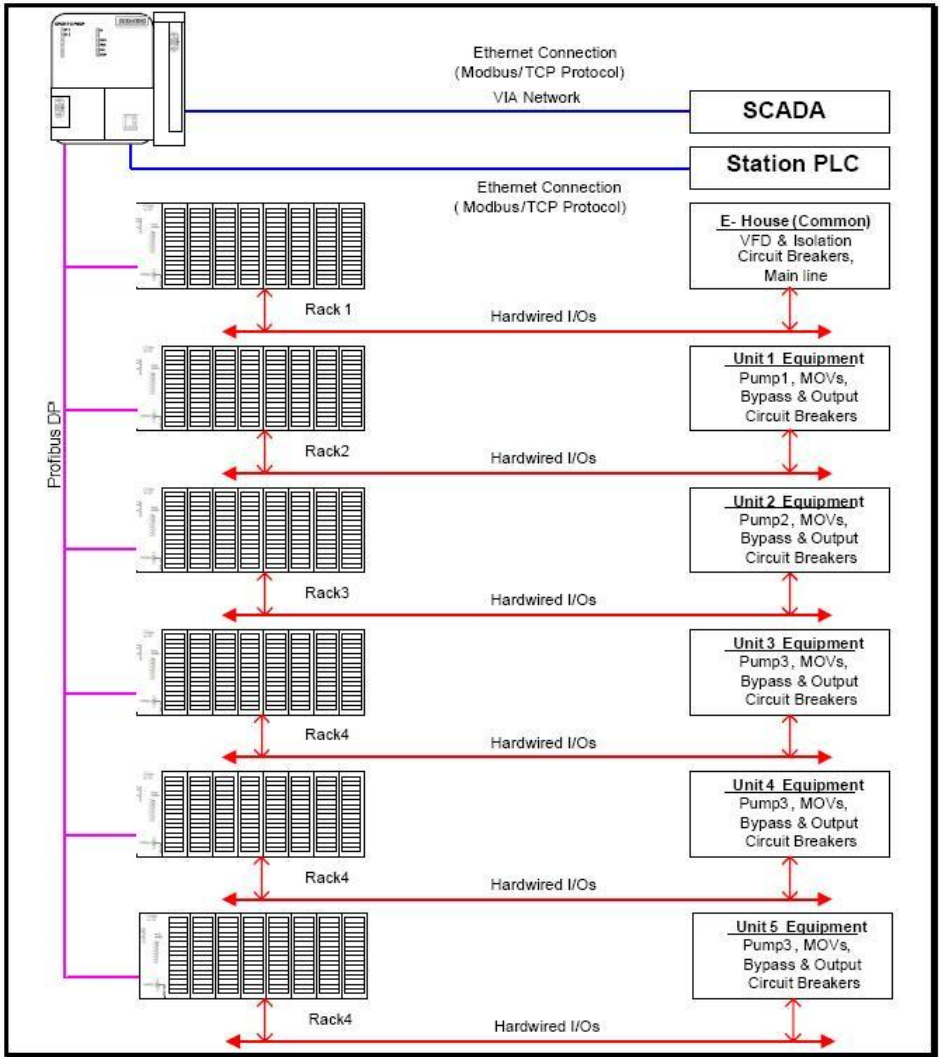
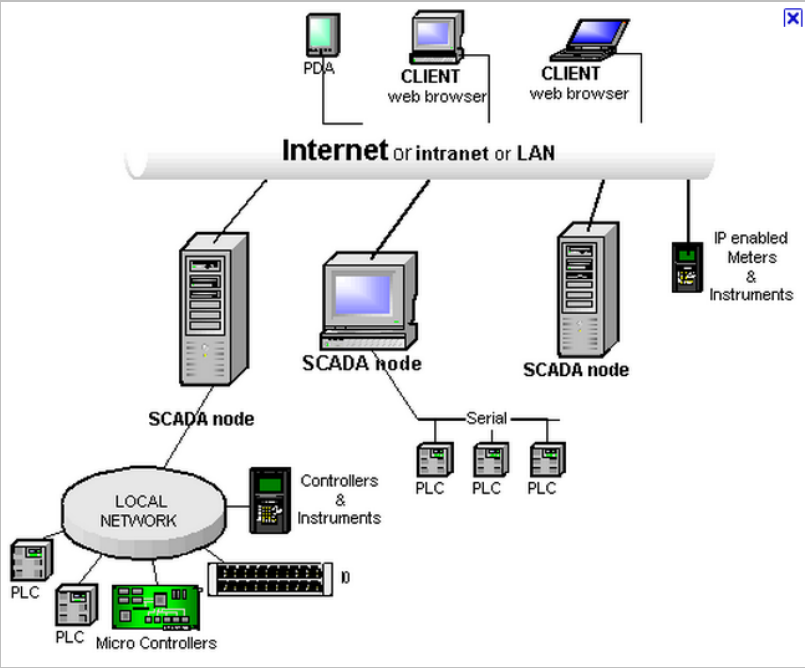

SCADA Control System

Network Diagrams of SCADA System

Example

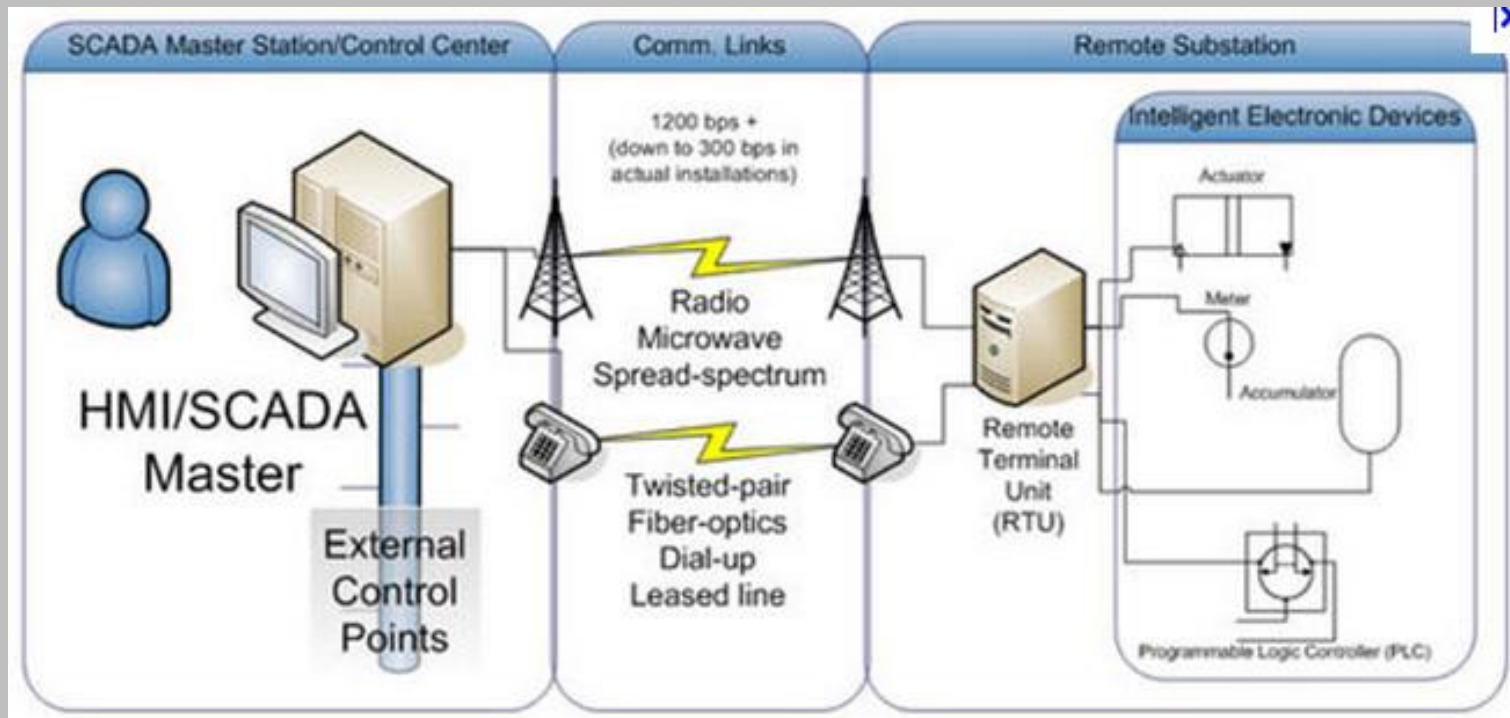

SCADA Control System

Network Diagrams of SCADA System

Example

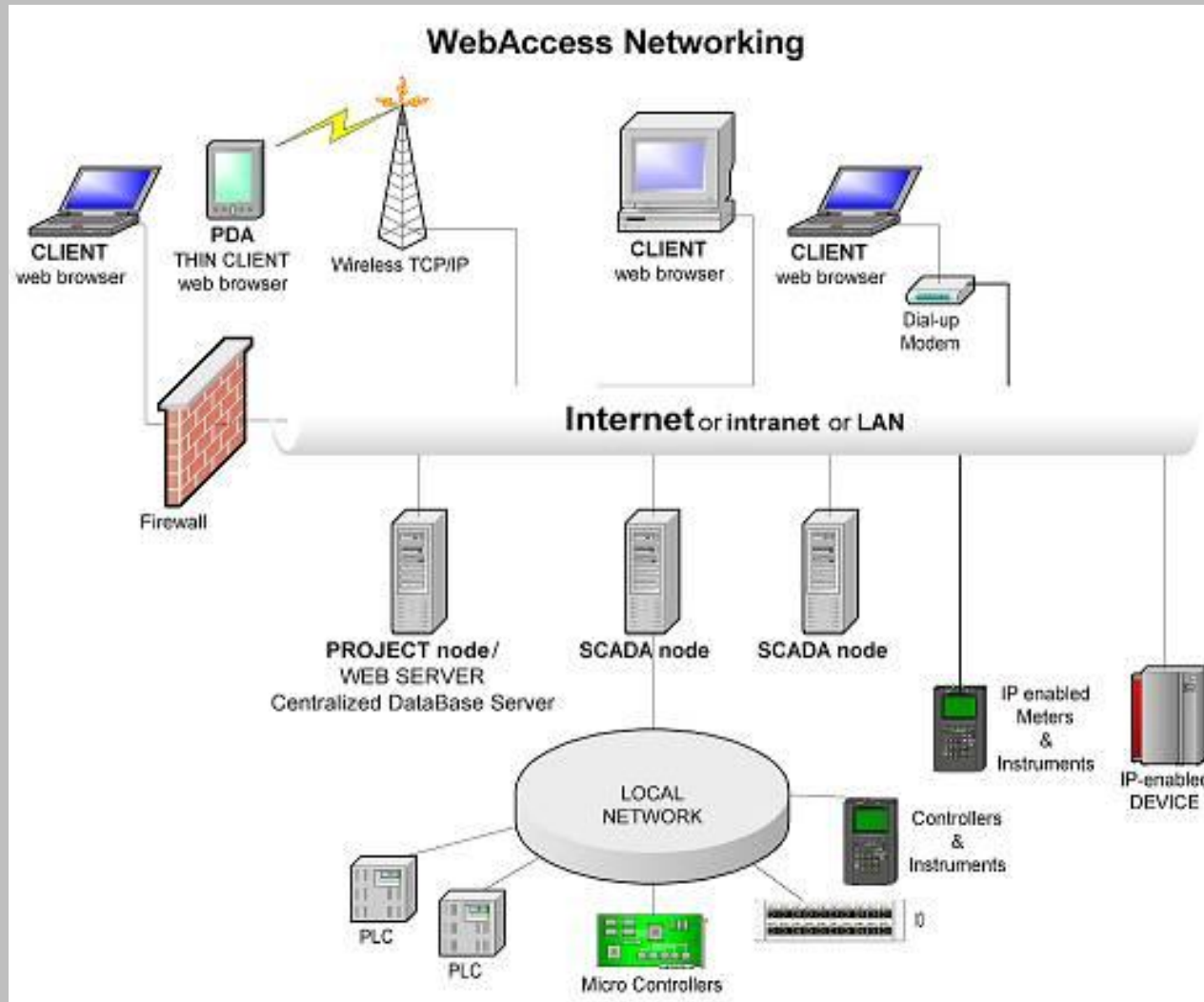

SCADA Control System

Capabilities of SCADA System

Most SCADA software provides a wide array of functions including

- Access to Live Data
- Custom Graphics Design and Display
- Alarm Generation and Display
- Data Logging and Historical Trending
- Custom Reports
- Scripts

Capabilities above can be lumped into single monolithic software application or made available as individual components in a suite.

SCADA Control System

Capability of SCADA System

Access to Live Data

Once Communication aspects of SCADA Software are configured, SCADA software poll the programmable controllers at the preset intervals.

Live and real time data is accessed by the SCADA Software and its components for Processing.

SCADA Control System

Capability of SCADA System

Custom Graphics Design and Display

User can design and display graphic representation of the plant with real time data displays, regularly refreshed, superimposed on graphics in the display, corresponding to their approximate location in the process.

Custom Graphics display is also called HMI (Human Machine Interface)

HMI Software is software application running on the operator consoles

It helps the operator to visualize the process

SCADA Control System

Capability of SCADA System

Custom Graphics Design and Display

True to life, animated process visualization is possible because of the built in, ready made symbols libraries included.

Customizable and dynamically updated screens mimic the process needs to be controlled.

Graphic screens grouped and linked in hierarchies where user can dig down to the status of individual instrument from overview screen of plant.

SCADA Control System

Capability of SCADA System

Custom Graphics Design and Display

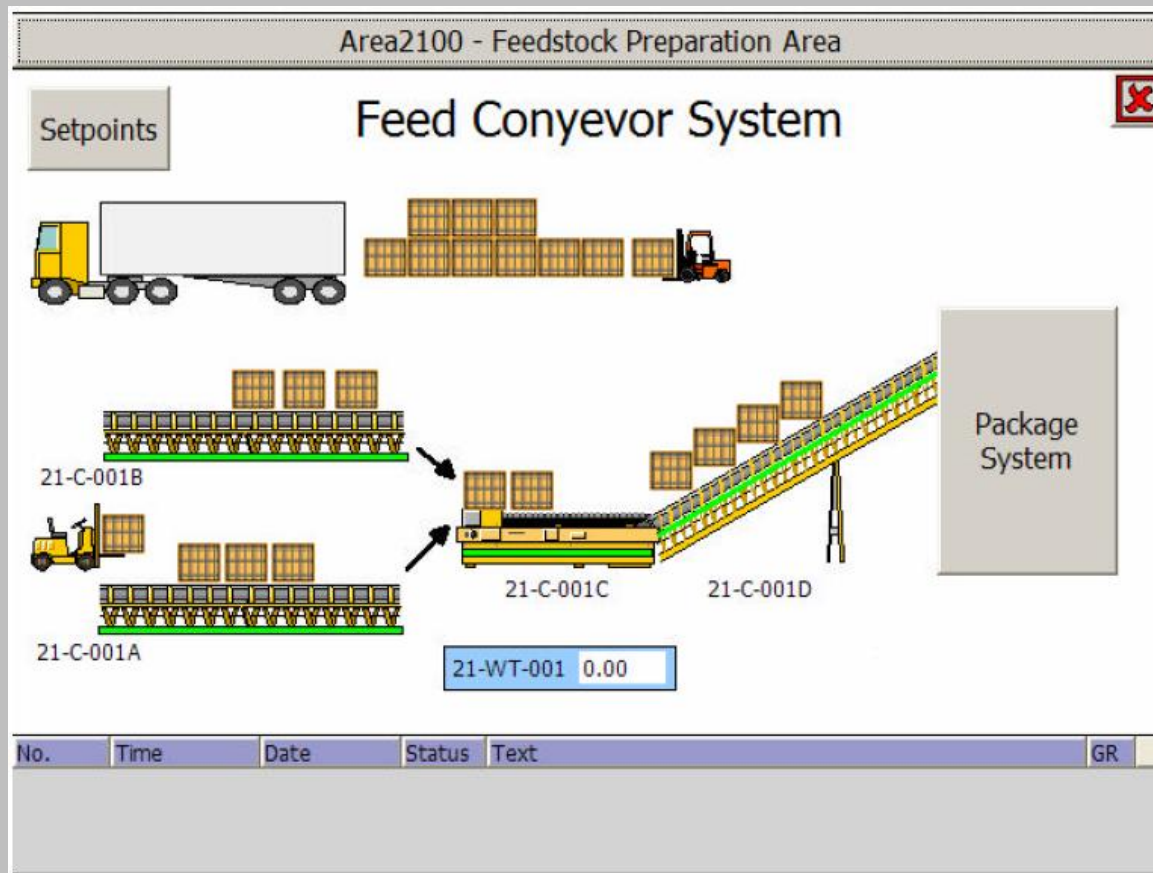

SCADA Control System

Capability of SCADA System

Custom Graphics Design and Display

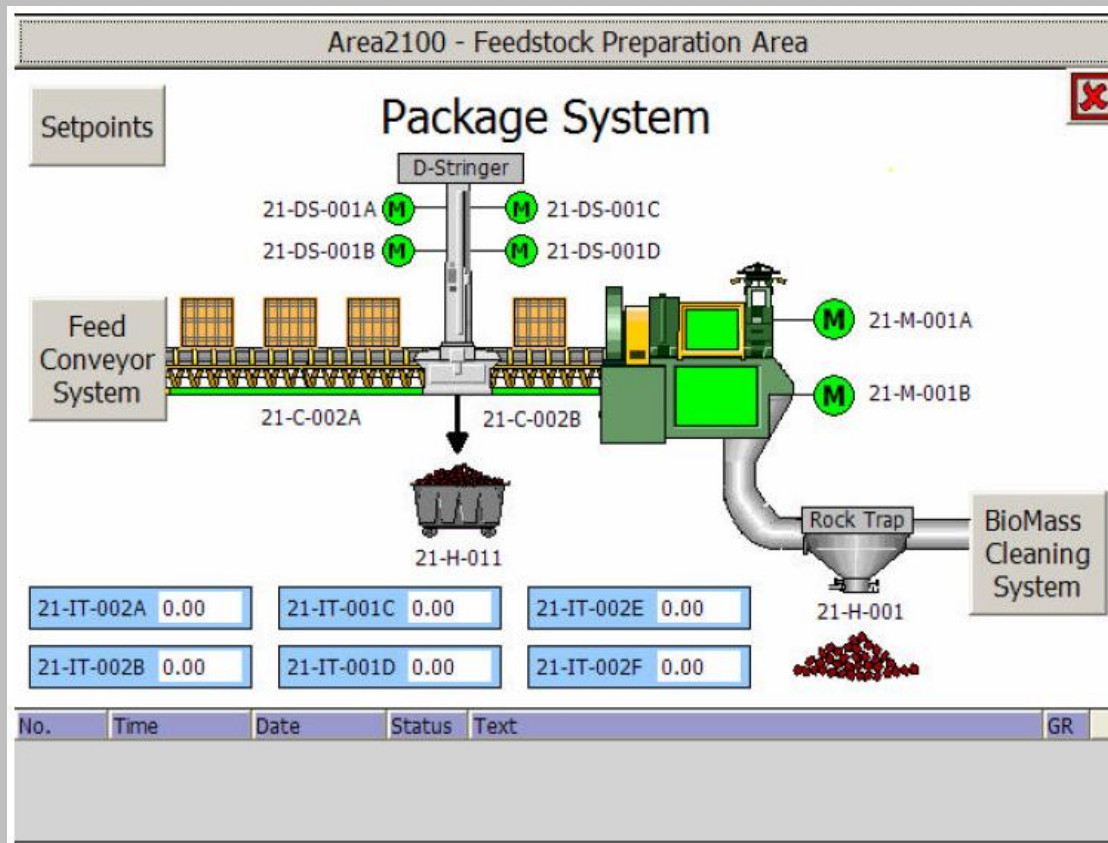

SCADA Control System

Capability of SCADA System

Custom Graphics Design and Display

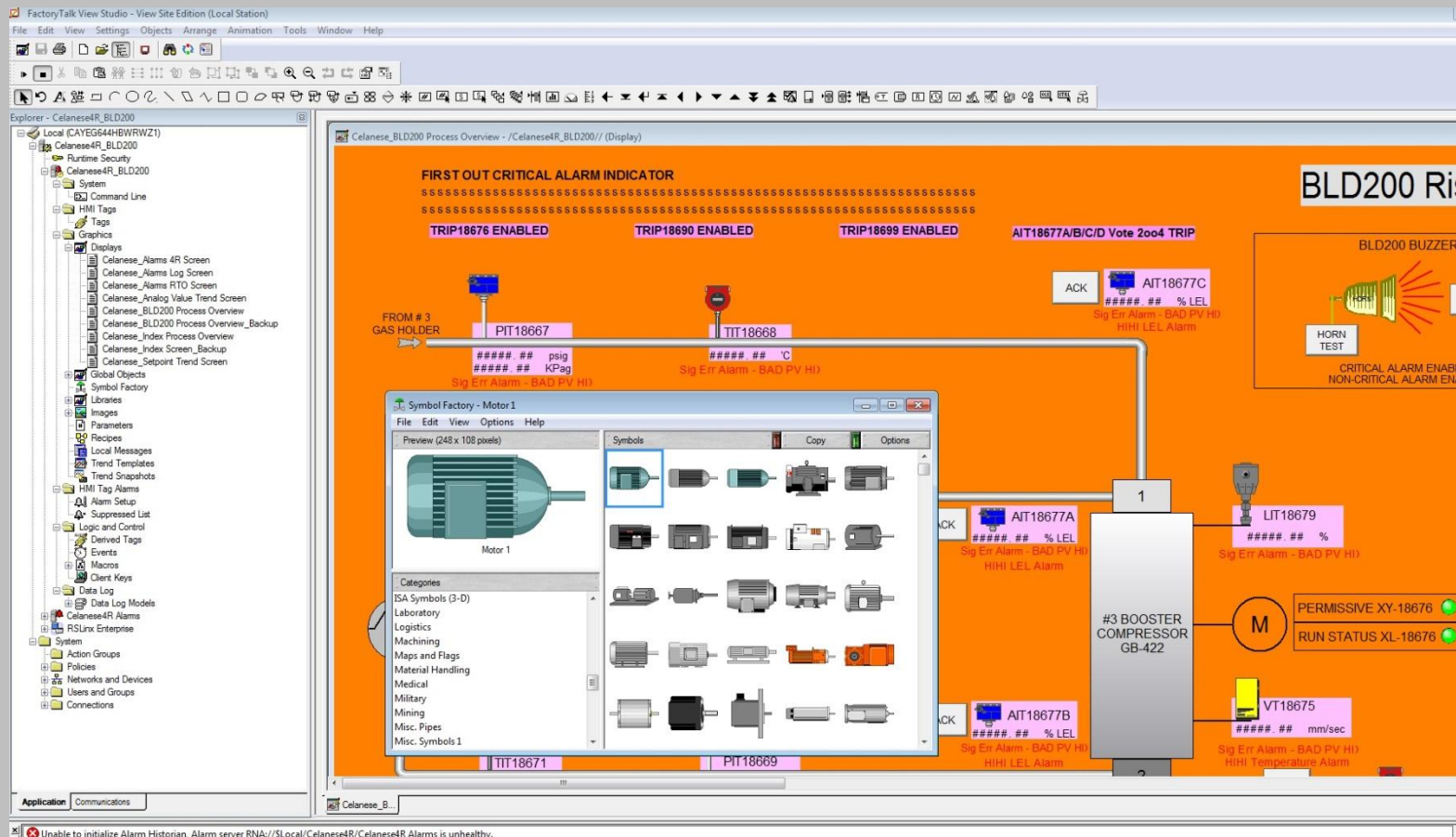

SCADA Control System

Capability of SCADA System

Custom Graphics Design and Display

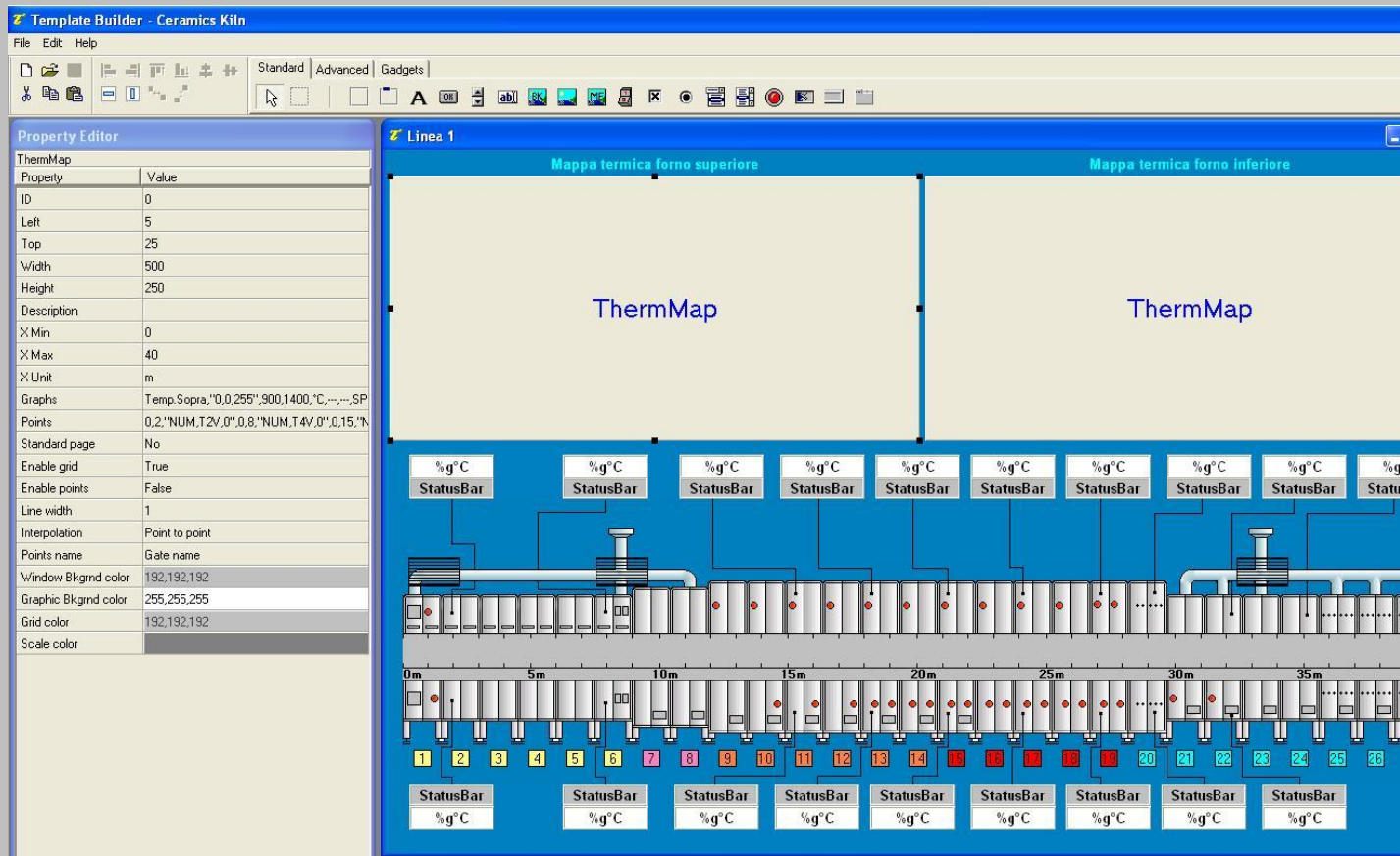

SCADA Control System

Capability of SCADA System

Custom Graphics Design and Display

The screenshot displays the Winlog Pro software interface. On the left is the 'Property Editor' for a 'CONTROL PANEL' template. The main window shows a custom-designed control panel with various gauges, meters, and indicators.

Property	Value
Name	CONTROL PANEL
Access group	0
Left	0
Top	0
Width	790
Height	501
BkColor	192,192,192
Gates	NUM,Pressure,1,NUM,Level,1,NUM,Temper
Open function	
Close function	
Hidden	False
Style	Fixed
Stay on top	False

The control panel features the following elements:

- Two large semi-circular gauges for 'PRESSURE' and 'LEVEL'.
- Two smaller semi-circular gauges for 'TEMPERATURE' and 'HUMIDITY'.
- Two linear meters for 'CURRENT' and 'VOLTAGE'.
- Two smaller semi-circular gauges for 'GAIN'.
- Four indicator lights (two red, two green).
- A 'GAIN METER' at the bottom with a color-coded scale.
- A 'SIGNAL ANALYZER' button on the right side.
- The 'WINLOG PRO' logo and 'SCADA/HMI SOFTWARE' text on the right side.

SCADA Control System

Capability of SCADA System

Alarm Generation and Display

User can define alarms for the automated process, which will cause a visible display on the operator console such as blinking red text with audible indication.

Alarms can be defined to have a time stamp and logged for later retrieval for analysis and review.

Alarms can be defined to split into categories on the base of severity or priority and different system operators can be given unique rights to see or acknowledge the alarms.

Alarm Generator monitors variables to detect level and deviation conditions such as HHHI, HI, LO and LOLO.

SCADA Control System

Capability of SCADA System

Alarm Generation and Display

Alarm configuration is a matter of creating an event area, hierarchical organization of the alarms, setting of limits and priorities.

Alarm summary display is embedded in the HMI graphics to display alarms as a list and permits the operator to acknowledge it.

SCADA Control System

Capability of SCADA System

Alarm Generation and Display

In Alarm summary, alarms can be sorted in any defined criteria.

Logged clients subscribe to alarms from SCADA servers but can specify alarm filters, filtering alarms on the base of area, type, priority etc

SCADA Control System

Capability of SCADA System

Alarm Generation and Display

The screenshot displays the 'BLD200 Alarm Screen' interface. At the top, there is a title bar with the text 'Celanese_BLD200 Alarms Screen - /Celanese4R/' and a central header 'BLD200 Alarm Screen'. To the right of the header is a button labeled 'ALARM LOG SCREEN' and a red 'X' icon. Below the header is a toolbar with various icons and a dropdown menu set to 'BLD200 Alarms'. The main area is a table with columns for 'Event Time', 'Alarm Name', and 'Message'. The table contains 25 rows of alarm data, all dated 11/2/2016 at 3:48:04 PM. The messages are 'Alarm fault cleared: Alarm input quality is good'. The status icons for each row vary, including red circles with exclamation marks, blue circles with exclamation marks, and yellow triangles with exclamation marks. At the bottom of the screen, there is a status bar with icons for '# 62', '3' (alarms), '0' (acknowledged), '59' (active), and '2' (help). The filter is set to 'BLD200 Alarms' and sorted by 'Event Time (Ascending)'. A message at the bottom left of the table area reads 'No message selected.'

Event Time	Alarm Name	Message
11/2/2016 3:48:04 PM	TIT_18681_HHAlarm_Latch	Alarm fault cleared: Alarm input quality is good
11/2/2016 3:48:04 PM	UA_18703B	POWER SUPPLY (UPS) FAULT ALARM
11/2/2016 3:48:04 PM	ZSO_18696A_Alarm_Latch	Alarm fault cleared: Alarm input quality is good
11/2/2016 3:48:04 PM	UA_18703A	POWER SUPPLY (UTILITY) FAULT ALARM
11/2/2016 3:48:04 PM	VT_18675_HHAlarm_Latch	Alarm fault cleared: Alarm input quality is good
11/2/2016 3:48:04 PM	..._18700_BadPVLoAlarm_Latch	Alarm fault cleared: Alarm input quality is good
11/2/2016 3:48:04 PM	..._18687_BadPVHiAlarm_Latch	Alarm fault cleared: Alarm input quality is good
11/2/2016 3:48:04 PM	..._18684_BadPVLoAlarm_Latch	Alarm fault cleared: Alarm input quality is good
11/2/2016 3:48:04 PM	TIT_18684_HHAlarm_Latch	Alarm fault cleared: Alarm input quality is good
11/2/2016 3:48:04 PM	VT_18687_HHAlarm_Latch	Alarm fault cleared: Alarm input quality is good
11/2/2016 3:48:04 PM	TIT_18689_HHAlarm_Latch	Alarm fault cleared: Alarm input quality is good
11/2/2016 3:48:04 PM	VT_18675_HIAlarm	Alarm fault cleared: Alarm input quality is good
11/2/2016 3:48:04 PM	..._18675_BadPVHiAlarm_Latch	Alarm fault cleared: Alarm input quality is good
11/2/2016 3:48:04 PM	TIT_18672_HIAlarm	Alarm fault cleared: Alarm input quality is good
11/2/2016 3:48:04 PM	UA_18701	POWER FEED MODULE FAULT ALARM
11/2/2016 3:48:04 PM	VT_18687_HIAlarm	Alarm fault cleared: Alarm input quality is good
11/2/2016 3:48:04 PM	UA_18693A_Alarm_Latch	Alarm fault cleared: Alarm input quality is good
11/2/2016 3:48:04 PM	TIT_18700_HIAlarm	Alarm fault cleared: Alarm input quality is good
11/2/2016 3:48:04 PM	TIT_18672_HHAlarm_Latch	Alarm fault cleared: Alarm input quality is good
11/2/2016 3:48:04 PM	TIT_18689_HIAlarm	Alarm fault cleared: Alarm input quality is good
11/2/2016 3:48:04 PM	UA_18693B_Alarm_Latch	Alarm fault cleared: Alarm input quality is good
11/2/2016 3:48:04 PM	TIT_18684_HIAlarm	Alarm fault cleared: Alarm input quality is good
11/2/2016 3:48:04 PM	UA_18677A_Alarm_Latch	Alarm fault cleared: Alarm input quality is good

SCADA Control System

Capability of SCADA System

Alarm Generation and Display

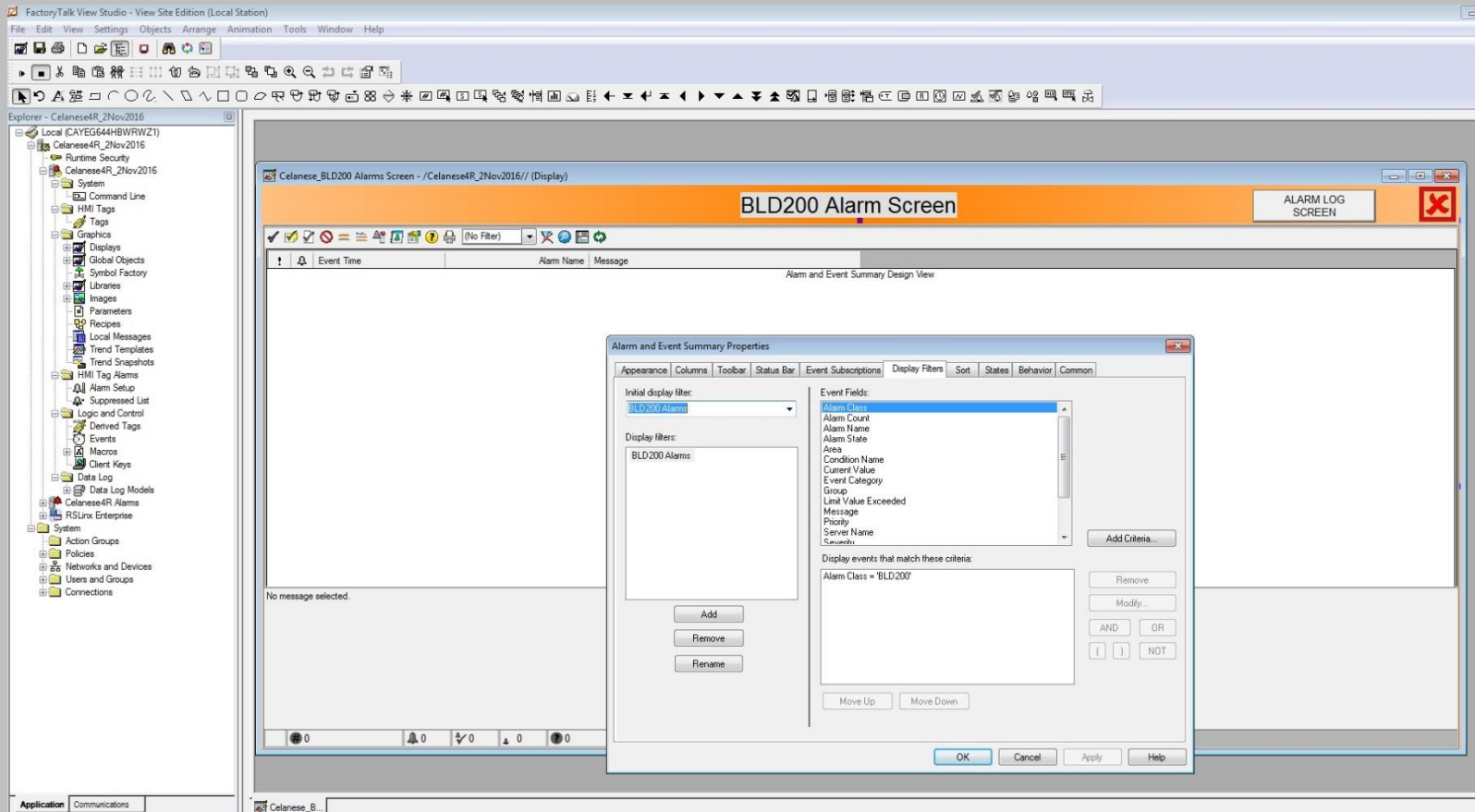

SCADA Control System

Capability of SCADA System

Alarm Generation and Display

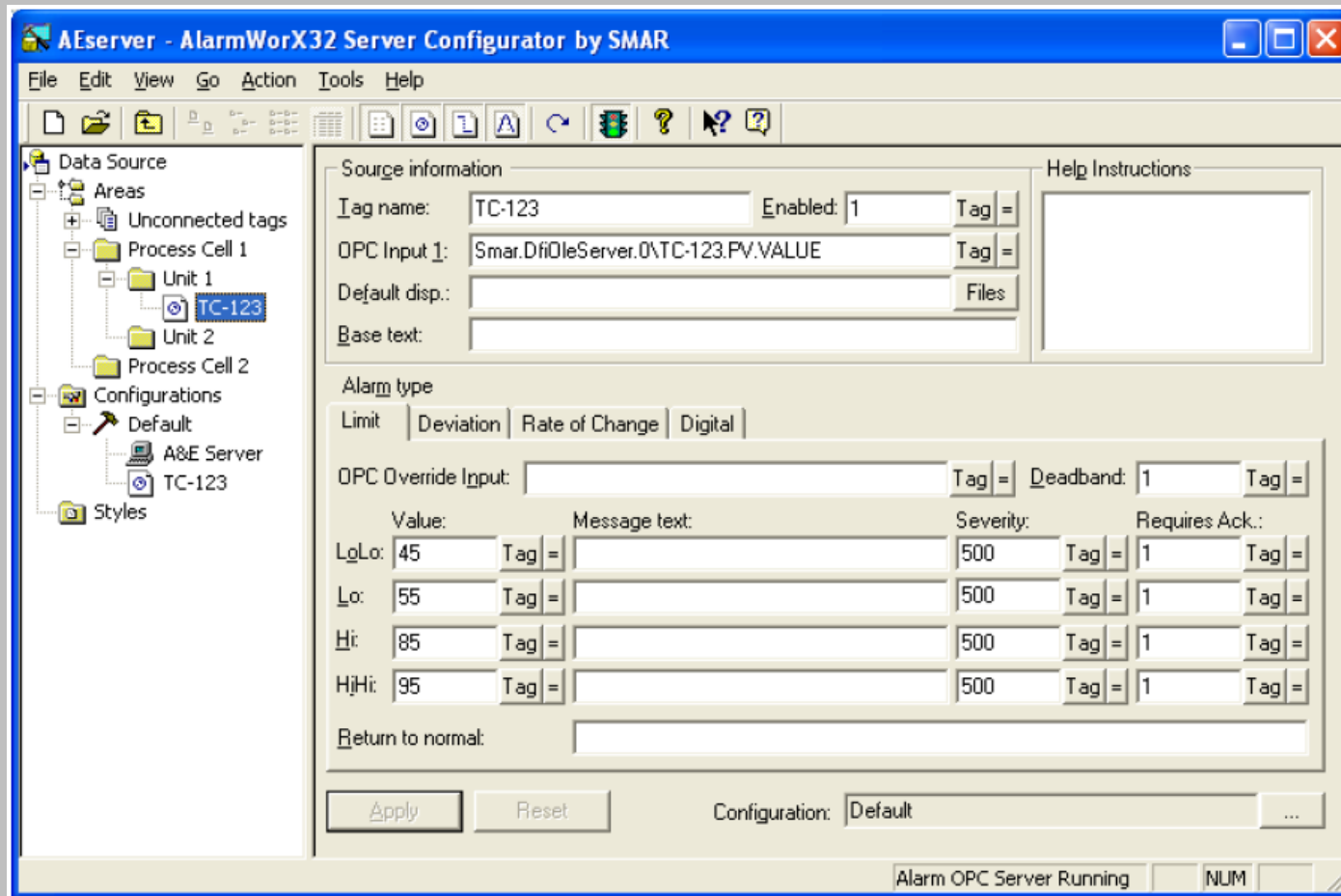

SCADA Control System

Capability of SCADA System

Alarm Generation and Display

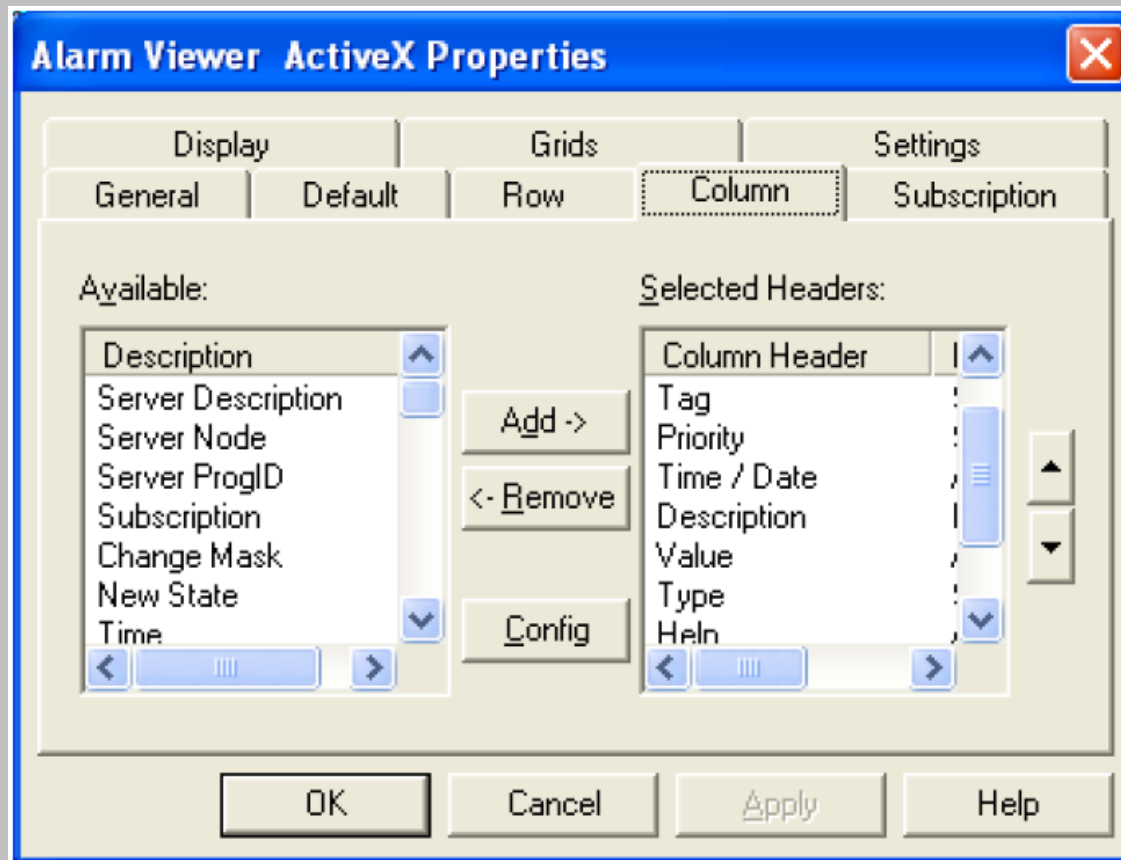

SCADA Control System

Capability of SCADA System

Alarm Generation and Display

Gate Builder - instrument demo

File Edit View Help

Gate ID	N ID	Message	Type	Gate ID	N ID	Operator	Fixed value	Filter time (s)	Class 1	Class 2	Is Alarm	Need Acknowledge	Record on historical file	Access groups	M1 Type	M1 Gate ID	M1 N ID	M	
1	Alarm_pressure_hi	1	Alarm - High Pressure - value %5.1f bar	CMP	Delta_pressure	1	3	3	0	1	High	T	F	T	0	NUM	Pressure	1	
2	Alarm_pressure_lo	1	Alarm - Low Pressure - value %f bar	CMP	Delta_pressure	1	5	-3	0	1	Low	T	F	T	0	NUM	Pressure	1	
3	Alarm_level_hi	1	Alarm - High Level - value %5.1f m	CMP	Delta_level	1	3	3	0	1	High	T	F	T	0	NUM	Level	1	
4	Alarm_level_lo	1	Alarm - Low Level - value %5.1f m	CMP	Delta_level	1	5	-3	0	1	Low	T	F	T	0	NUM	Level	1	
5	Alarm_temperature_hi	1	Alarm - High Temperature - value %5.1f °C	CMP	Delta_temperature	1	3	3	0	1	High	T	F	T	0	NUM	Temperature	1	
6	Alarm_temperature_lo	1	Alarm - Low Temperature - value %5.1f °C	CMP	Delta_temperature	1	5	-3	0	1	Low	T	F	T	0	NUM	Temperature	1	
7	Alarm_humidity_hi	1	Event - High Humidity - value %5.1f %	CMP	Delta_humidity	1	3	1	0	1	High	F	F	T	0	NUM	Humidity	1	
8	Alarm_humidity_lo	1	Event - Low Humidity - value %5.1f %	CMP	Delta_humidity	1	5	-1	0	1	Low	F	F	T	0	NUM	Humidity	1	
9	Alarm_current_hi	1	Event - High Current - value %5.1f A	CMP	Delta_current	1	3	1	0	1	High	F	F	T	0	NUM	Current	1	
10	Alarm_current_lo	1	Event - Low Current - value %5.1f A	CMP	Delta_current	1	5	-1	0	1	Low	F	F	T	0	NUM	Current	1	
11	Alarm_voltage_hi	1	Event - High Voltage - value %5.1f V	CMP	Delta_voltage	1	3	1	0	1	High	F	F	T	0	NUM	Voltage	1	
12	Alarm_voltage_lo	1	Event - Low Voltage - value %5.1f V	CMP	Delta_voltage	1	5	-1	0	1	Low	F	F	T	0	NUM	Voltage	1	
13	Alarm_gain_hi	1	Event - High Gain - value %5.1f	CMP	Delta_gain	1	3	1	0	1	High	F	F	T	0	NUM	Gain	1	
14	Alarm_gain_lo	1	Event - Low Gain - value %5.1f	CMP	Delta_gain	1	5	-1	0	1	Low	F	F	T	0	NUM	Gain	1	

Event gates

General Condition Message Class

Condition gate

Type Gate ID N ID

CMP Delta_gain 1 [Choose...]

Operator

< [v]

Compare

Fixed value Gate

-1

Filter time (s)

0

Ok Cancel Help

SCADA Control System

Capability of SCADA System

Data Logging and Historical Trending

SCADA Software includes Data Logger which logs the data in the underlying database engine i.e. SQL

Groups of parameters are created for different sampling or polling rates

Logged data can be processed and analysed to calculate Average, Minimum, Maximum and Totals etc

Trend Viewer can display logged data in different types of graphs for customized ranges

SCADA Control System

Capability of SCADA System

Data Logging and Historical Trending

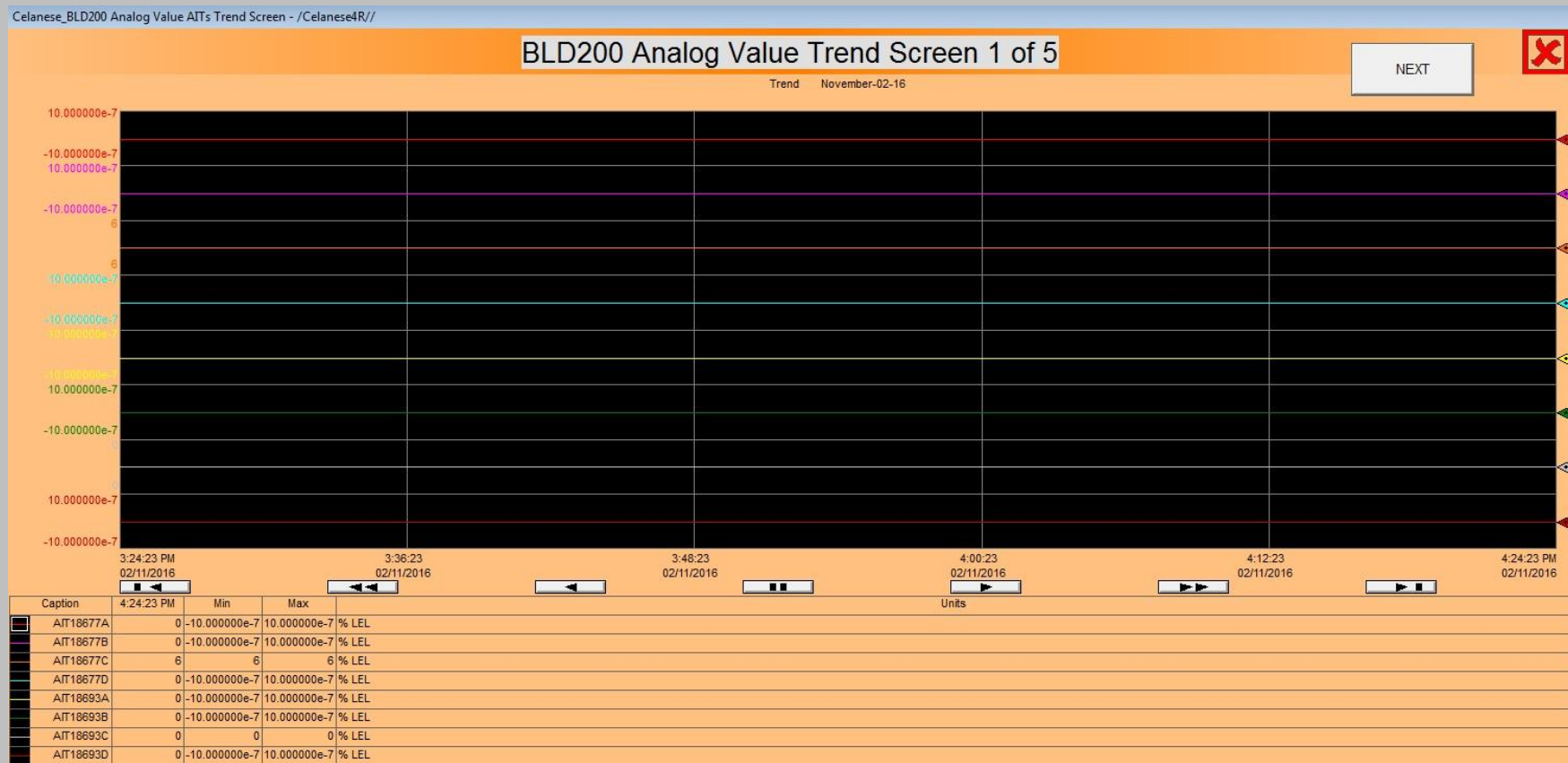

SCADA Control System

Capability of SCADA System

Data Logging and Historical Trending

The screenshot displays a SCADA system interface with three main components:

- Project Explorer (Left):** A tree view showing the project structure for 'Celanese4R_2Nov2016'. It includes folders for System, HMI Tags, Graphics, Displays, Global Objects, Symbol Factory, Libraries, Images, Parameters, Recipes, Local Messages, Trend Templates, Trend Snapshots, HMI Tag Alarms, Alarm Setup, Suppressed List, Logic and Control, Derived Tags, Events, Macros, Client Keys, Data Log, Data Log Models, Celanese4R Alarms, RSLinx Enterprise, System, Action Groups, Policies, Networks and Devices, Users and Groups, and Connections.
- Trend Screen (Center):** A window titled 'Celanese_BLD200 Analog Value AITs Trend Screen - /Celanese4R_2Nov2016// (Display)'. It shows a grid for plotting trends. The title bar indicates 'BLD200 Analog Value Trend Screen 1 of 5'. The x-axis is labeled 'Trend' and the y-axis is labeled 'September-29-15'. The grid is currently empty.
- Trend Properties Dialog (Right):** A dialog box with tabs for General, Display, Pens, X-Axis, Y-Axis, Overlays, Template, Runtime, and Common. The 'Pens' tab is active, showing a table of pen attributes for eight data points.

Tag Expr.	Model	Color	Visible
{(BLD200)AIT_18677A.Value}	CelaneseBLD200AnalogAITsValues ...	Red	On
{(BLD200)AIT_18677B.Value}	CelaneseBLD200AnalogAITsValues ...	Magenta	On
{(BLD200)AIT_18677C.Value}	CelaneseBLD200AnalogAITsValues ...	Cyan	On
{(BLD200)AIT_18677D.Value}	CelaneseBLD200AnalogAITsValues ...	Blue	On
{(BLD200)AIT_18693A.Value}	CelaneseBLD200AnalogAITsValues ...	Yellow	On
{(BLD200)AIT_18693B.Value}	CelaneseBLD200AnalogAITsValues ...	Green	On
{(BLD200)AIT_18693C.Value}	CelaneseBLD200AnalogAITsValues ...	Light Green	On
{(BLD200)AIT_18693D.Value}	CelaneseBLD200AnalogAITsValues ...	Red	On

Pen Source: Tag (Live Data) Add Pen(s)... Delete Pen(s)

Visible	Width	Type	Style	Marker	Min	Max	Eng. Units
<input type="checkbox"/>							

Multiple Pen Edits

Clear Selections Apply to Selected Pen(s)

OK Cancel Apply Help

SCADA Control System

Capability of SCADA System

Data Logging and Historical Trending

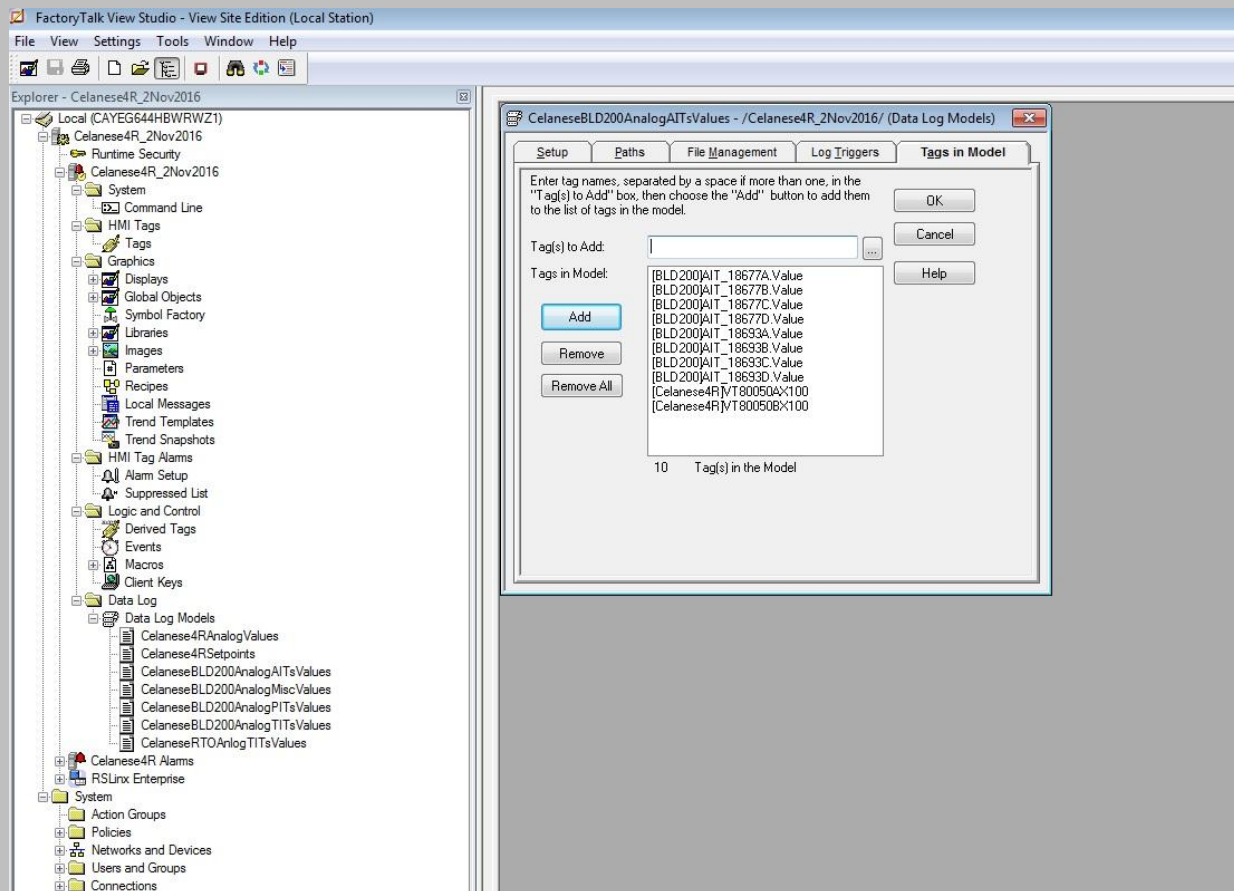

SCADA Control System

Capability of SCADA System

Data Logging and Historical Trending

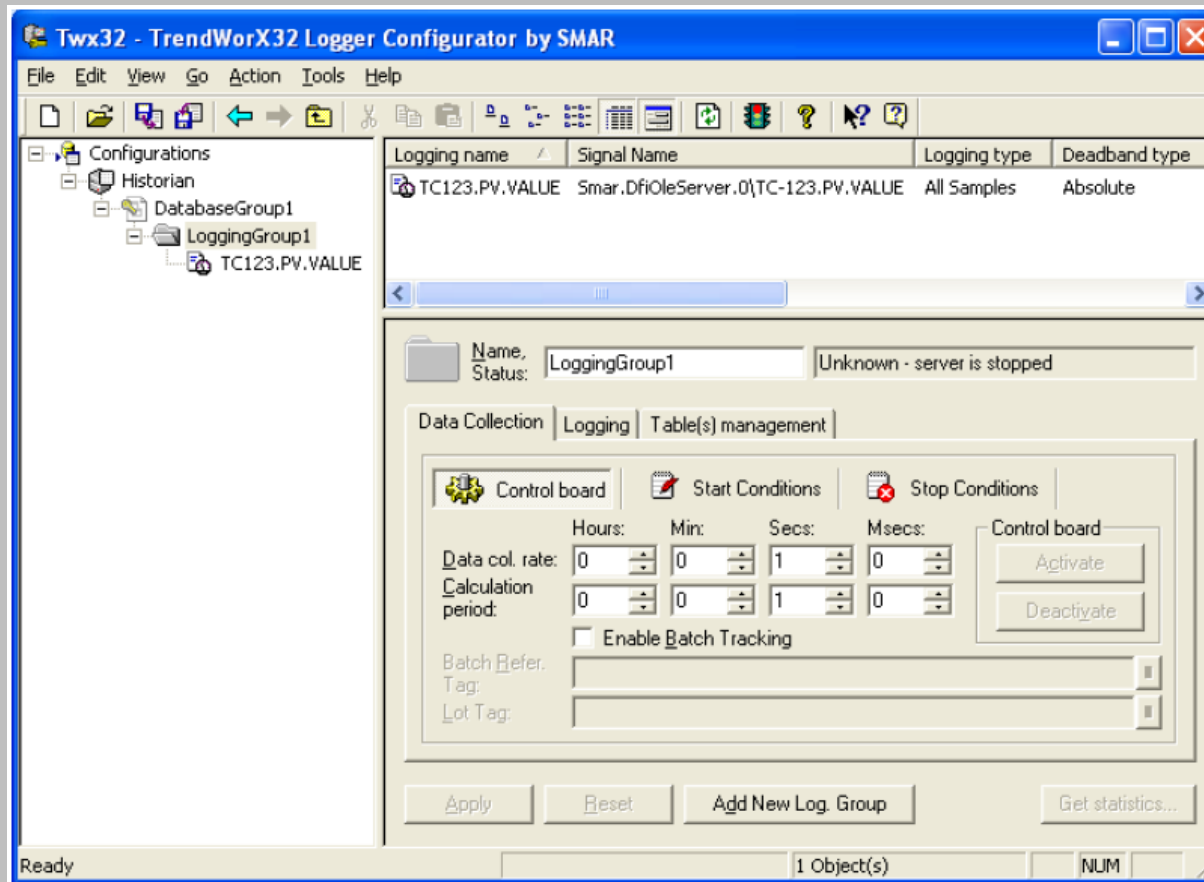

SCADA Control System

Capability of SCADA System

Data Logging and Historical Trending

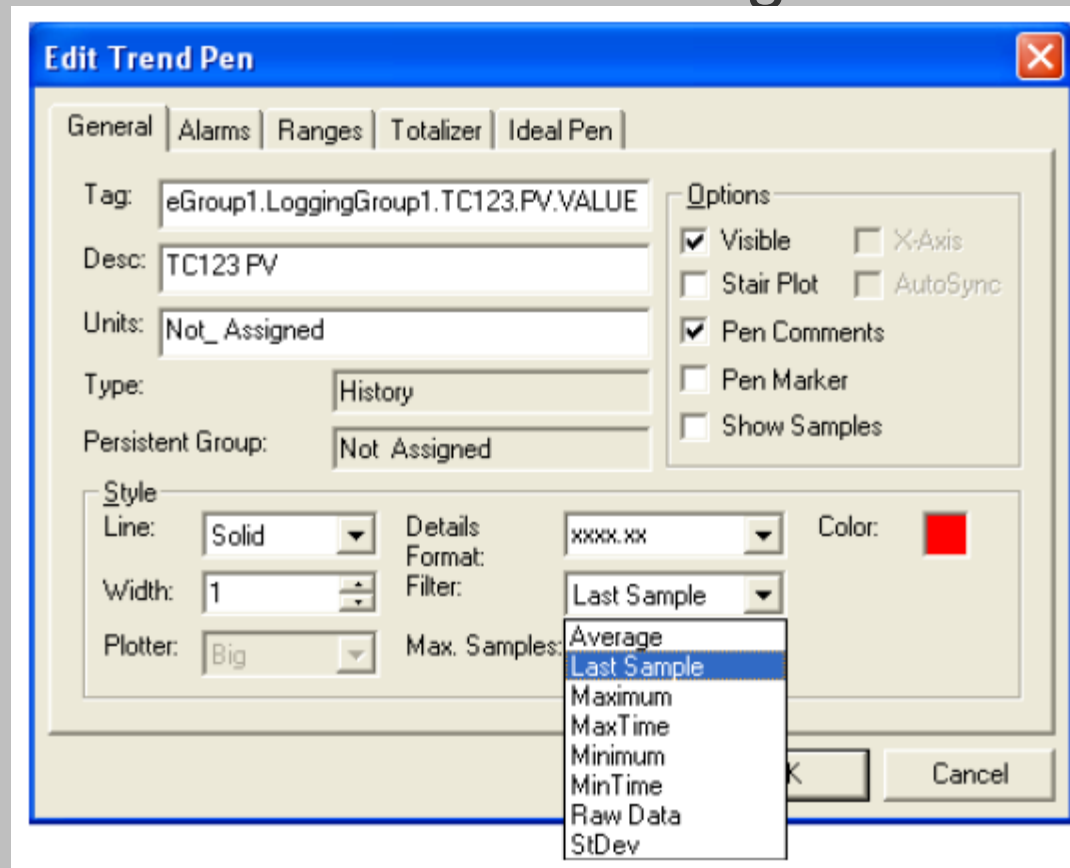

SCADA Control System

Capability of SCADA System

Data Logging and Historical Trending

The screenshot displays the 'Gate Builder - instrument demo' application. The main window contains a table with the following columns: Channel, Device, Gate ID, N ID, Address, Description, Start value, Sample, Sample frequency (s), Read block, Record on historical file, Enable writing to device, and Access groups. The table lists 14 channels, including pressure control, level control, and current/voltage setpoints.

Channel	Device	Gate ID	N ID	Address	Description	Start value	Sample	Sample frequency (s)	Read block	Record on historical file	Enable writing to device	Access groups
1	0	Pressure_control_on	1		Pressure control enable (slider 1)	0	Never			F	T	0
2	0	Pressure_control_on	2		Pressure control enable (dial)	0	Never			F	T	0
3	0	Pressure_control_on	3		Pressure control enable (slider 2)	0	Never			F	T	0
4	0	Level_control_on	1		Pressure control enable (slider 1)	0	Never			F	T	0
5	0	Level_control_on	2		Pressure control enable (dial)	0	Never			F	T	0
6	0	Level_control_on	3		Pressure control enable (slider 2)	0	Never			F	T	0
7	0	Current_set	1		Current setpoint 20	0	Never			F	T	0
8	0	Current_set	2		Current setpoint 40	0	Never			F	T	0
9	0	Current_set	3		Current setpoint 60	0	Never			F	T	0
10	0	Current_set	4		Current setpoint 80	0	Never			F	T	0
11	0	Voltage_set	1		Voltage setpoint +10	0	Never			F	T	0
12	0	Voltage_set	2		Voltage setpoint +10	0	Never			F	T	0
13	0	Voltage_set	3		Voltage setpoint +10	0	Never			F	T	0
14	0	Voltage_set	4		Voltage setpoint +10	0	Never			F	T	0

The 'Digital gates' dialog box is open, showing the 'General' tab. It contains the following fields and options:

- Gate ID: Pressure_control_on
- N ID: 1
- Description: Pressure control enable (slider 1)
- Access groups: [Empty field] Choose...
- Record on historical file:
- Enable writing to device:

Buttons: Ok, Cancel, Help

SCADA Control System

Capability of SCADA System

Custom Reports

The logged data can be extracted from underlying SQL database to generate reports based on some filter criteria.

Historical Trend loggers and alarm or event loggers usually have an accompanying reporting tool which can be configured to extract information from the database and present it in a predefined layout.

SCADA Control System

Capability of SCADA System

Custom Reports

Report Viewer may be embedded into graphics or may be stand alone tool which can be launched in SCADA application.

Report configuration may include designing report format and selecting when the report shall be generated i.e. daily, weekly, monthly etc

Reports can be printed, sent via email or can be saved in different formats.

SCADA Control System

Capability of SCADA System

Custom Reports

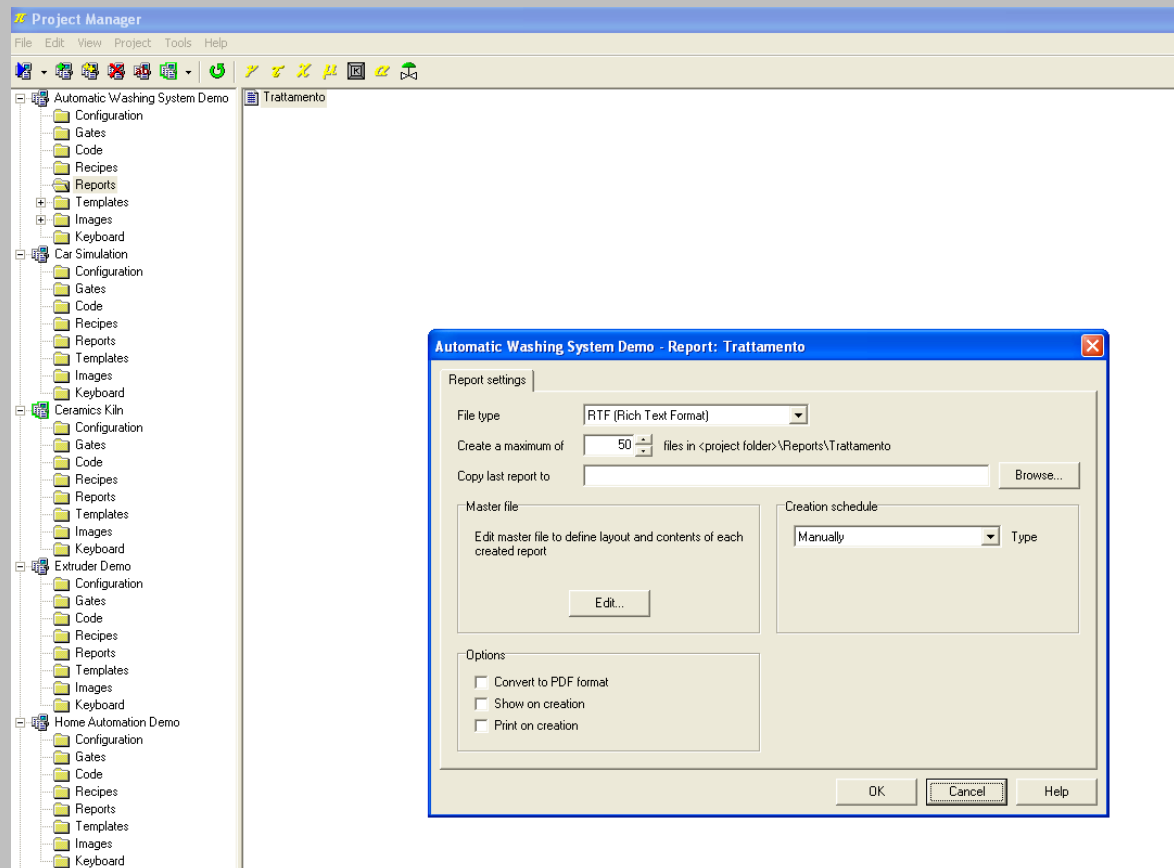

SCADA Control System

Capability of SCADA System

Scripts

VBA language is the primary language used for HMI Scripts.

Elements of VBA are functions, statements, methods, objects and events.

VBA functions permit sophisticated scripts to perform all kinds of tasks including program flow control, data conversion, file management, file access, arithmetic, comparison and logic.

Familiar keywords include IF-THEN-ELSE, FOR-NEXT, GO TO etc

SCADA Control System

Capability of SCADA System

Scripts

The screenshot displays the FactoryTalk View Studio interface. On the left is a project tree for 'Celanese4R_2Nov2016'. The main window shows a macro file with the following content:

```
----- Macro File created 09/30/2015 -----  
! Macros are lists of commands, with one command per line  
! See Help or the manual for a list of commands and their parameters  
-----  
DataLogOn Celanese4RAnalogValues  
DataLogOn Celanese4RSetpoints  
DataLogOn CelaneseBLD200AnalogAITsValues  
DataLogOn CelaneseBLD200AnalogMiscValues  
DataLogOn CelaneseBLD200AnalogPITsValues  
DataLogOn CelaneseBLD200AnalogTITsValues  
DataLogOn CelaneseRT0AnalogTITsValues
```

A 'Command Wizard Step 1 of 2' dialog is open, showing a list of commands. The 'DataLogChangeRate' command is selected. Below the list, the command syntax is shown: `DataLogChangeRate <file> <value> [units]`. The description reads: 'Changes the periodic logging interval.'

Command Categories	Commands	Name	Description	Syntax
Most Recently Used				
All Commands and Macros				
System				
Tag and Database				
External Applications				
Multimedia				
Framework				
Languages				
Security				
Activity Log				
Graphics				
Graphic Displays				
Recipe Management				
Alarms				
Data Log				
Logic and Control				
Derived Tags				
Display Client				
Events				
Flow Control				
Client Keys				
Macros				

SCADA Control System

Capability of SCADA System

Scripts

```
Code Builder - [Automatic Washing System Demo\ProcessesConfiguration.wil]
File Edit Search Syntax checking Window Help
ProcessesConfiguration
2 // Applicazione: PREMIUM - CIP
3 // Modulo: ProcessesConfiguration
4 //
5 // Funzioni di gestione del caricamento/salvataggio e cancellazione
6 // ricette di trattamento
7 //-----
8
9 //*****
10 // loadProcess
11 //
12 // Carica la ricetta associata al trattamento il cui nome è selezionato nella
13 // FileListBox (porta 'Rec proc title')
14 //*****
15 function void loadProcess()
16
17     string fileName;
18     string recipeName;
19     bool error = false;
20
21     // Esce se nessun trattamento è stato selezionato
22     if (GetStrGateValue("Rec_proc_title", 0) == "") then return; end
23
24     // Controlla se il file di ricetta esiste
25     recipeName = GetStrGateValue("Rec_proc_title", 0);
26     fileName = GetProjectPath() + "\Recipes\Trattamenti.rcf\" + recipeName + ".rcf";
27
28     if (FileExist(fileName) == false) then
29         // Il file non esiste, mostra errore
30         error = true;
31     else
32         if (RecipeExecute("Trattamenti", recipeName, false) == false) then
33             // Il caricamento ha dato problemi, mostra errore
34             error = true;
35         end
36     end
37
38     // Mostra errore se richiesto
39     if (error == true) then
40         IconMessageBox("Impossibile aprire il trattamento '" + recipeName + "'", "Errore", 2, 6, 1);
41     end
42 end
43
44 //*****
45 // saveProcess
```

SCADA Control System

Commonly used SCADA Software

Some commonly used SCADA Software are below

- iFIX by Intellution
- Wonderware by InTouch
- WinCC and WinCC Flex by Siemens
- FactoryTalk SE and ME by Rockwell Automation
- Genesis by Iconics
- eXLerate by SpritIT
- CitectSCADA by Schneider Electric

SCADA Control System

Commonly used SCADA Software

Some commonly used OpenSource SCADA Software are below

- WinLog Lite by Sielco Sistemi
- OpenControl by Buraq Integrated Solutions
- IGSS by 7-technologies
- Free SCADA
- SZARP
- Argos
- Mango
- IntegraXor

SCADA Control System

SCADA System Design Objective

User Friendly Application according to User Requirements

Easy to understand Interface

Hierarchical structure of screen with easy screen Navigation

Consistency of SCADA Application

Scalable design

SCADA Control System

SCADA System Design Objective

Less user training involved

User able to check the status of field devices and be able to control the devices manually via HMI or via Auto Code of PLC

User be able to easily troubleshoot failure

SCADA Control System

SCADA System Design Challenges

Hierarchical organization of the process

Creating prototypes of the devices

Issues with SCADA Software and its Hot Fixes

Trying to make Pop-ups or faceplates work

Communication issues between PLC and HMI

Issues with SCADA Software Scripting

SCADA Control System

SCADA System Design Challenges

Example of issues with SCADA Software scripting

```
If (SmartTags("22KV043.OP_STS")= 1 And SmartTags("22KV043.CL_STS")= 0) Then
    A22_DigFeedSys_KV43=1
Else If (SmartTags("22KV043.OP_STS")= 0 And SmartTags("22KV043.CL_STS")= 1) Then
    A22_DigFeedSys_KV43=2
Else
    A22_DigFeedSys_KV43=3
End If
End If
```

OR

```
If (SmartTags("22KV043.OP_STS")= True And SmartTags("22KV043.CL_STS")= False) Then
    A22_DigFeedSys_KV43=1
Else If (SmartTags("22KV043.OP_STS")= False And SmartTags("22KV043.CL_STS")= True) Then
    A22_DigFeedSys_KV43=2
Else
    A22_DigFeedSys_KV43=3
End If
End If
```

SCADA Control System

Control System Documentation

Different Types of Control System Documentation includes

- PFD (Process Flow Diagram)
- P&ID (Piping and Instrumentation Diagram)
- Process Control Narrative
- Instrument List
- Input/ Output List
- Specification Form
- Logic Diagrams
- Cause & Effect Sheets

SCADA Control System

Control System Documentation

Different Types of Control System Documentation includes

- Instrument Location Drawings
- Loop Diagrams
- Standards and Regulations
- FAT (Factory Acceptance Sheets)
- SAT (Site Acceptance Sheets)
- Operation Manuals

SCADA Control System

Example Projects

- Water Pumping Stations
- Emission Reduction System
- Pumping Station

SCADA Control System

Example Projects

Water Pumping Stations

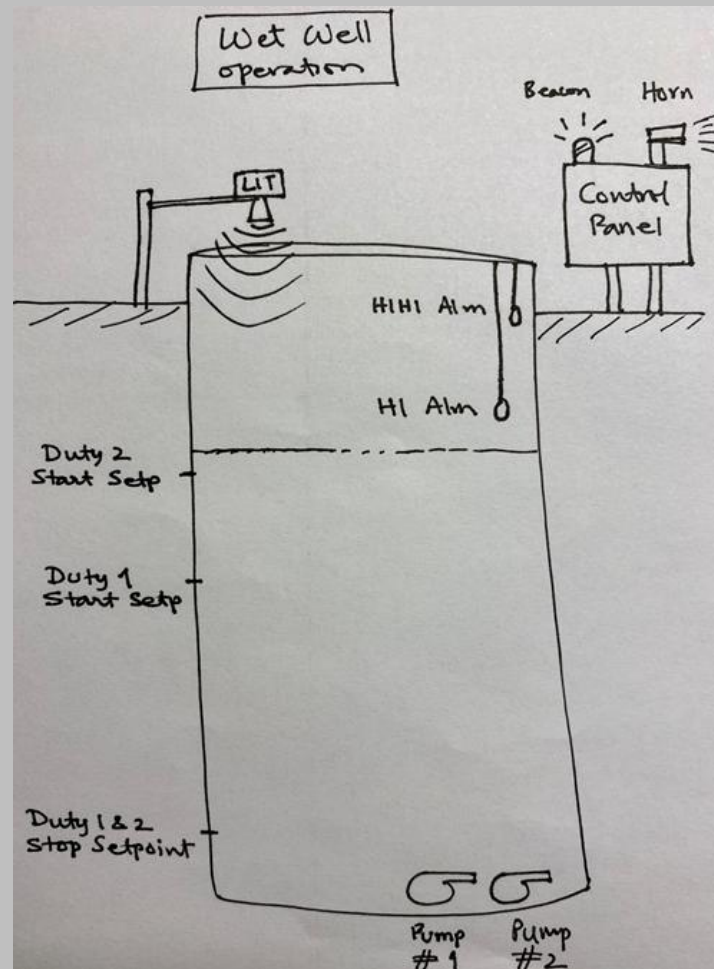

SCADA Control System

Example Projects

Water Pumping Stations

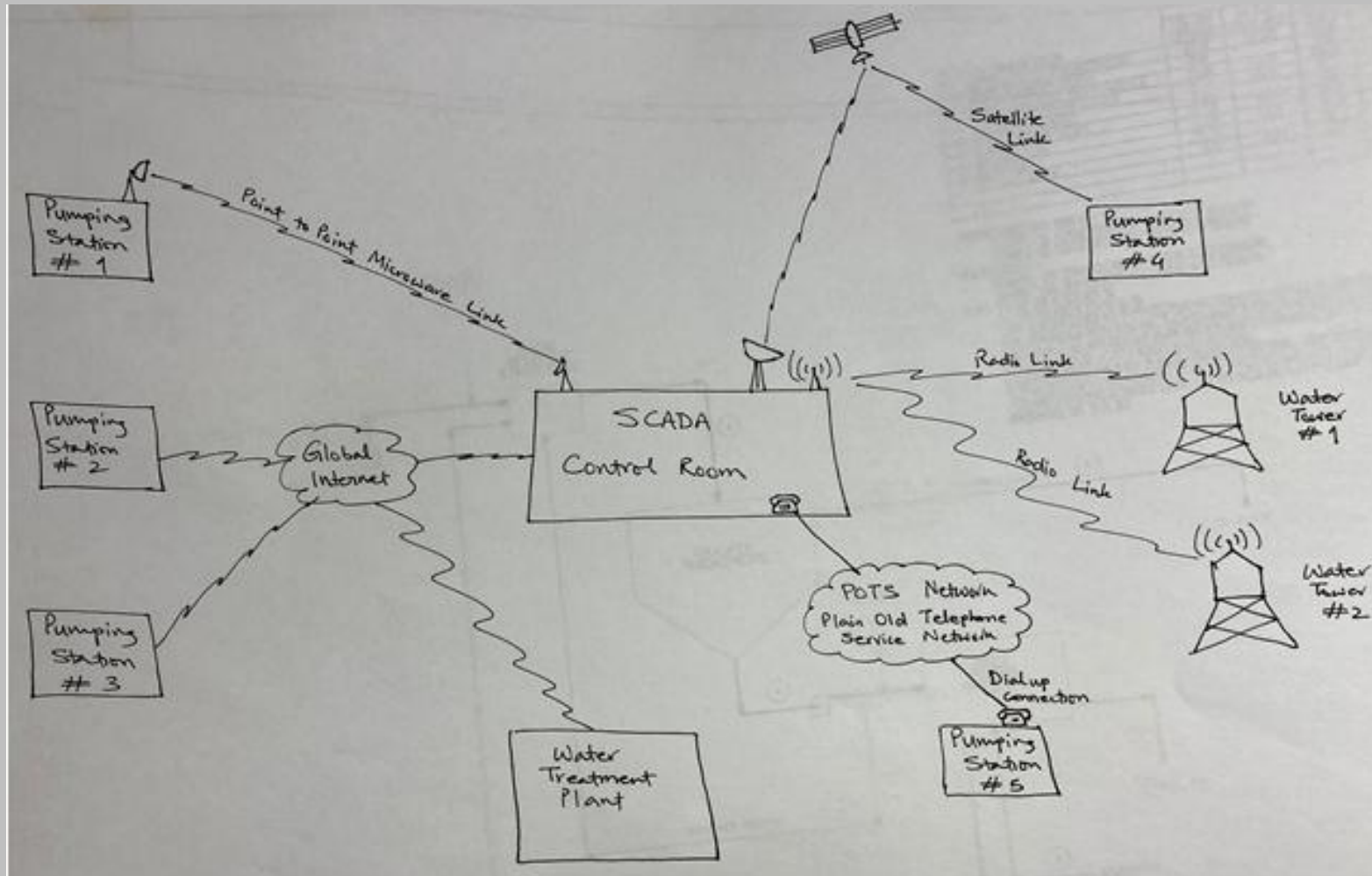

SCADA Control System

Example Projects

Project: Pumping Stations

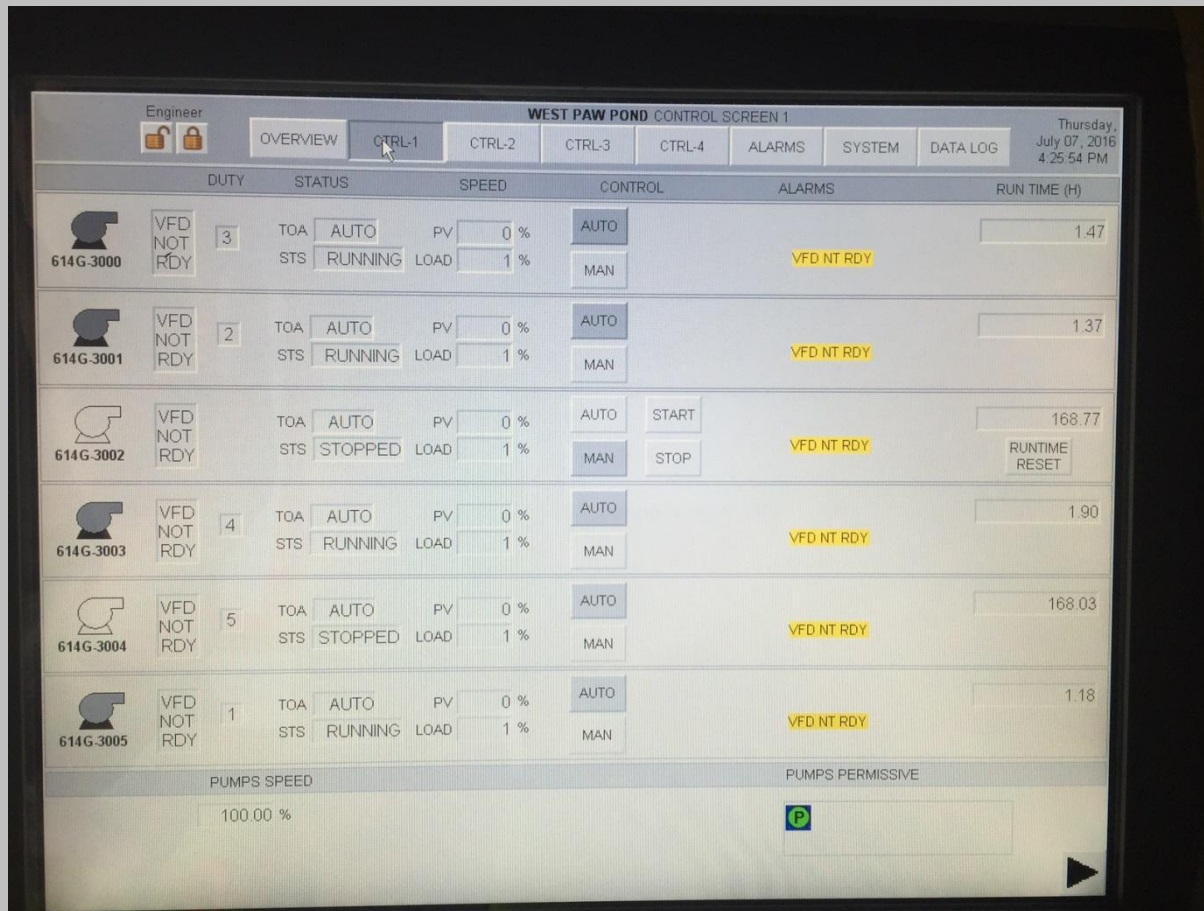

SCADA Control System

Example Projects

Project: Pumping Stations

Engineer
WEST PAW POND CONTROL SCREEN 2
Thursday, July 07, 2016 4:26:16 PM

OVERVIEW CTRL-1 CTRL-2 CTRL-3 CTRL-4 ALARMS SYSTEM DATA LOG

VALVE	STATUS	CONTROL	ALARMS
HV30007 CLOSECMD	L/R REM STATUS CLOSED	AUTO MAN	
HV30009 CLOSECMD	L/R REM STATUS CLOSED	AUTO MAN	

INSTRUMENT	MOS	PV LL ALM SETP	PV LO ALM SETP	PV HI ALM SETP	PV HH ALM SETP
AT30001 12.50 % LEL	ON OFF			25.00	30.00
AT30004 3.13 PPMV	ON OFF			5.00	10.00

	PV LO ALM SETP	PV HI ALM SETP	FC30006 FLOW SETP (SP)
FT30006 4500.00 m3/h	1 PUMPS RUNNING: 540 2 PUMPS RUNNING: 1080 3 PUMPS RUNNING: 1620 4 PUMPS RUNNING: 2160 5 PUMPS RUNNING: 2700 6 PUMPS RUNNING: 2700	1 PUMPS RUNNING: 1400 2 PUMPS RUNNING: 2800 3 PUMPS RUNNING: 4200 4 PUMPS RUNNING: 5600 5 PUMPS RUNNING: 7000 6 PUMPS RUNNING: 0	DTY 1 RUNNING: 1318 DTY 1 & 2 RUNNING: 2236 DTY 1, 2 & 3 RUNNING: 3954 DTY 1, 2, 3 & 4 RUNNING: 5272 DTY 1, 2, 3, 4 & 5 RUNNING: 6590 DTY 1, 2, 3, 4, 5 & 6 RUNNING: 7500

SCADA Control System

Example Projects

Project: Pumping Stations

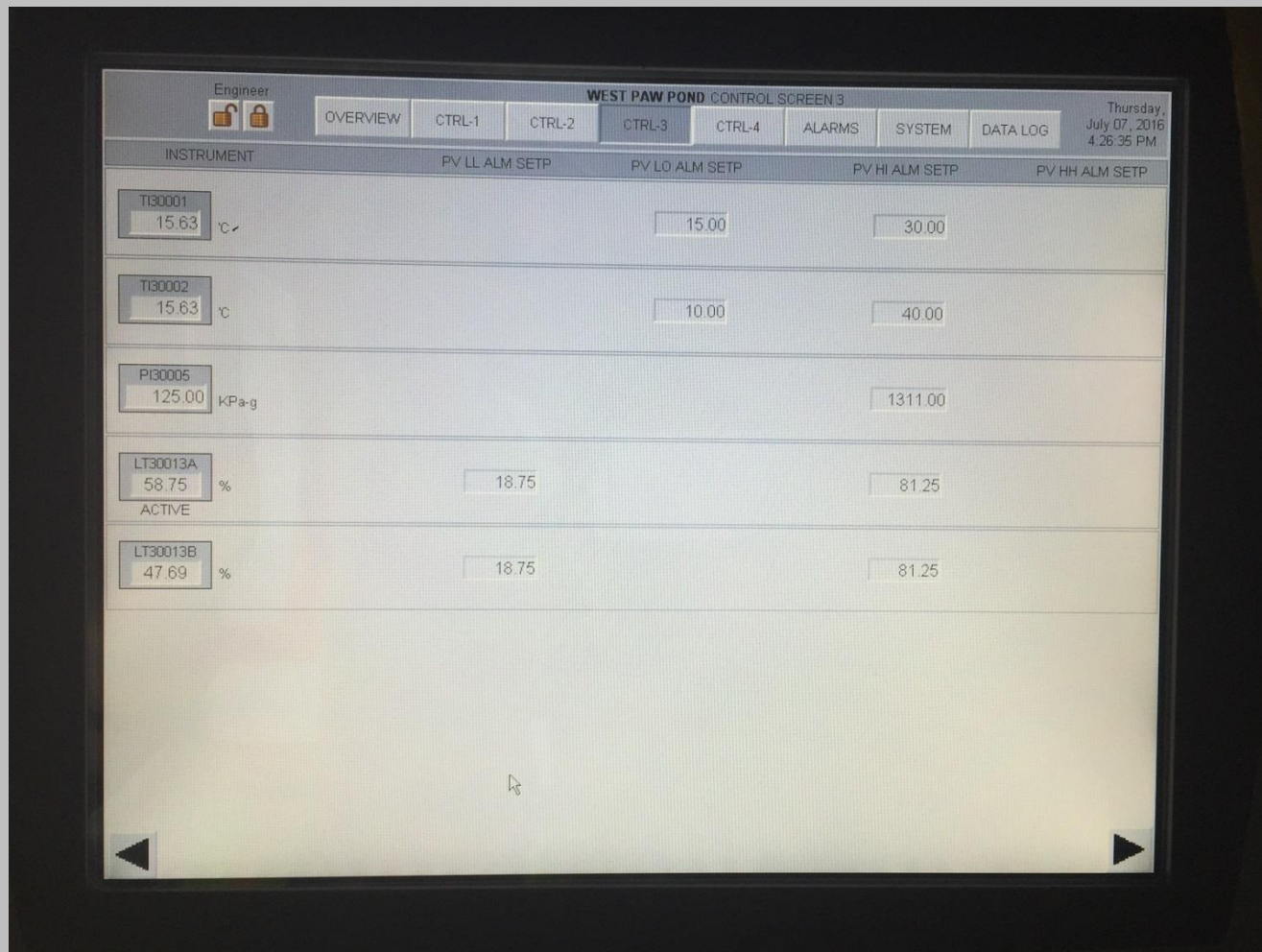

SCADA Control System

Example Projects

Project: Pumping Stations

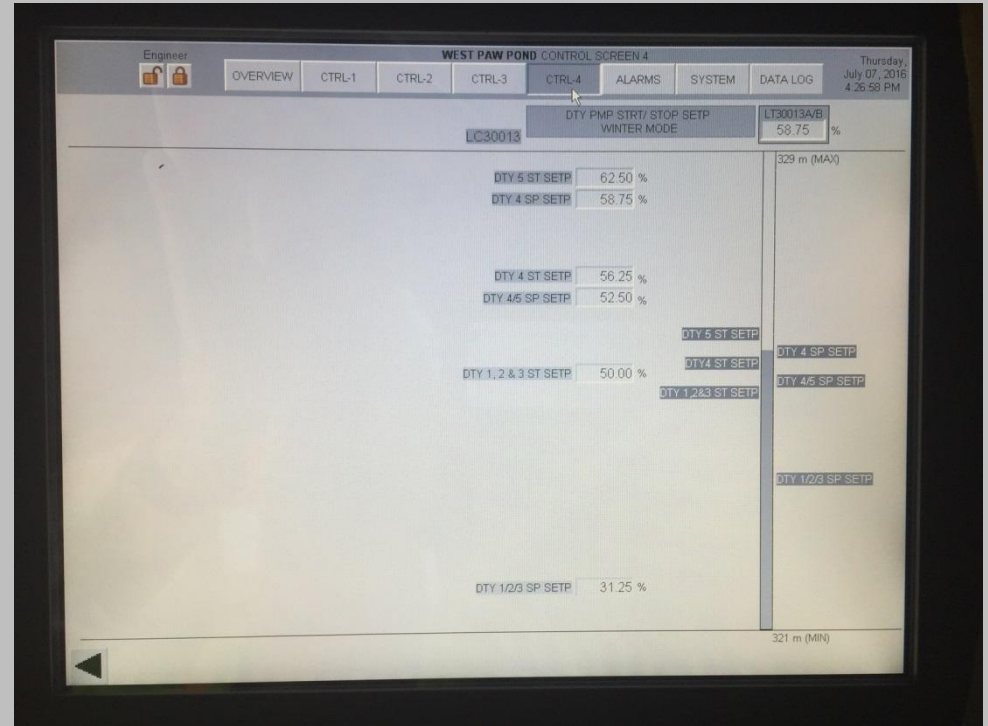
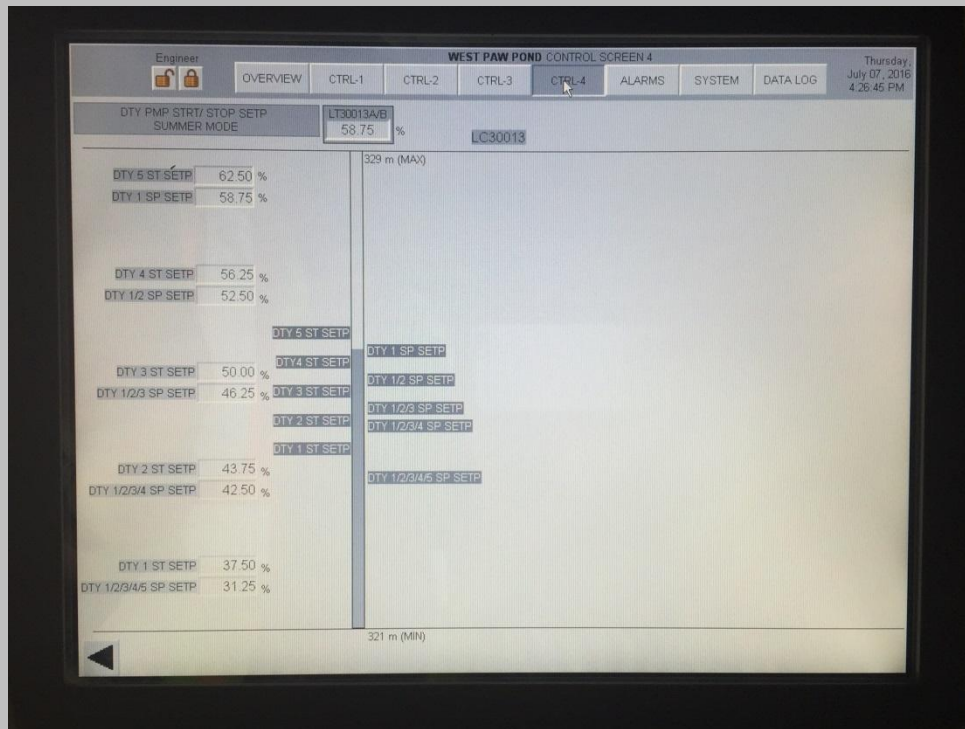

SCADA Control System

Example Projects

Project: Pumping Stations

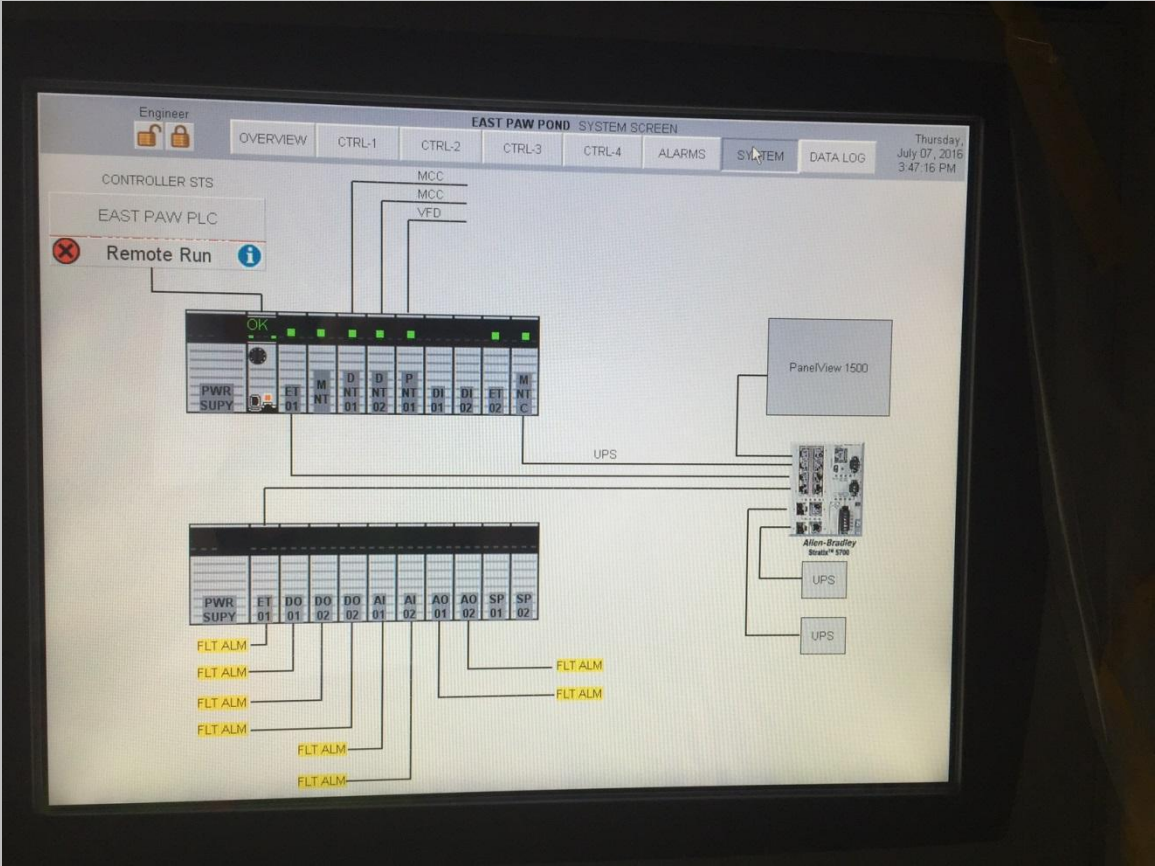

SCADA Control System

Example Projects

Project: Pumping Stations

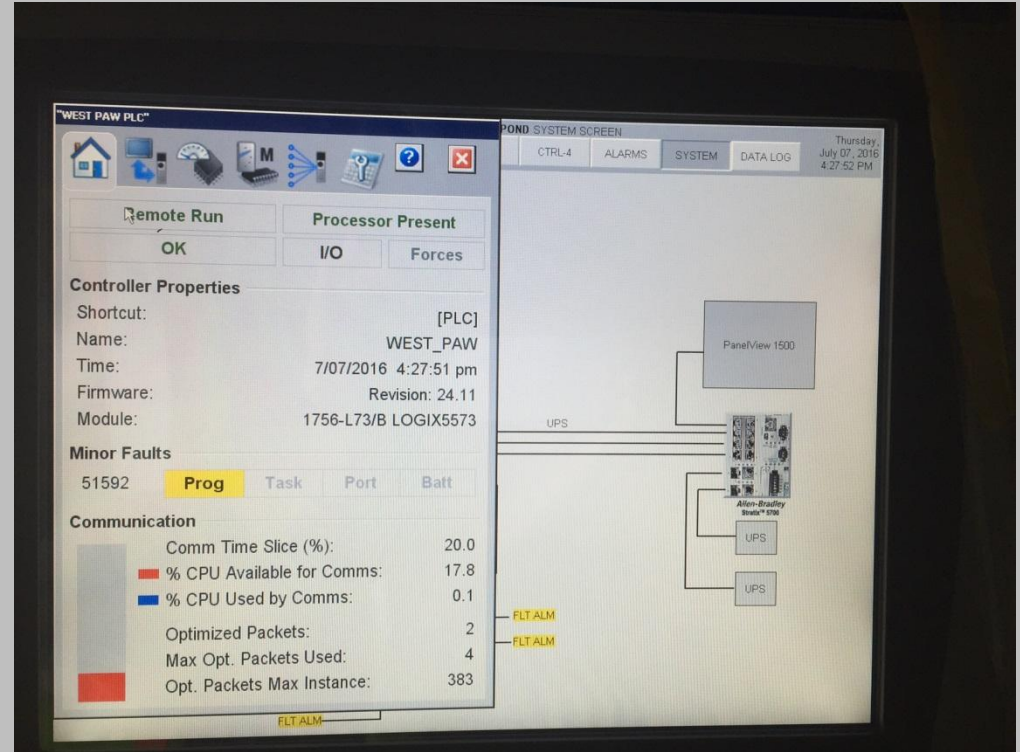
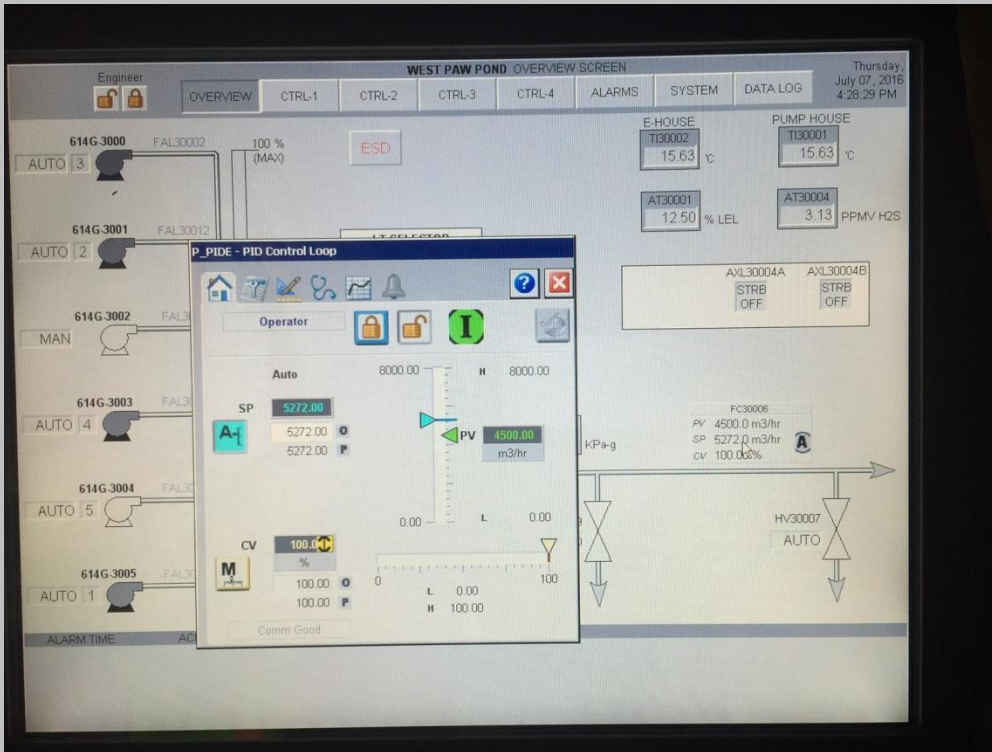

SCADA Control System

Example Projects in Transportation

- Remote monitoring of Subways and Metros
- Remote monitoring and control of
 - Traffic signals,
 - Rail track signals,
 - Railroad crossing gates
- Remote monitoring, Control and data acquisition of unmanned vehicles for preventive maintenance
- Regulates traffic lights, remote control of traffic flow and detection of out-of-order signals

If there is an interest, next proposed session can be

- Basics of Control System
- Evolution of Control System
- Types of Control System
- Basics of PLC Control System
- Features of PLC and its benefits
- Application of PLC
- PLC Hardware
- Basics of Relay Logic and its comparison with PLC
- Applications of PLC and Relay Logic (Interlocks)

SCADA of MKB Enterprises (Pvt) Ltd Plant

3/3/2025 3:03:18 PM

MKB Enterprises (Pvt) Ltd

Main Screen

Machine 1



6

Machine 2



0

Machine 3



3

Machine 4



0

Machine 5



0

Machine 6



1

Activate Windows
Go to Settings to activate Windows

Machines Configuration

About







SCADA of MKB Enterprises (Pvt) Ltd Plant

3/3/2025 3:04:00 PM

MKB Enterprises (Pvt) Ltd

Machines Configuration Screen

Main Machine 1 Production Machine 2 Production Machine 3 Production Machine 4 Production Machine 5 Production Machine 6 Production

Machines	Machines Status	Shift Selection	Card Selection
Machine 1	Not Running	Day  Night	160
NTD - WALK			
Machine 2	Running	Day  Night	143
Machine 3	Running	Day  Night	160
Machine 4	Running	Day  Night	160
Machine 5	Not Running	Day  Night	156
Machine 6	Not Running	Day  Night	160

Activate Windows
Go to Settings to activate Windows.

SCADA of MKB Enterprises (Pvt) Ltd Plant

3/3/2025 3:05:27 PM

MKB Enterprises (Pvt) Ltd

Machines 3 Production Screen

Main Configuration

Machine 3 Machines Status: Running Machine Shift: Day

Production

Shift 4

Daily 4

Weekly 4

Monthly 4

Machine 3 Day Salary 4

Click Close

Activate Windows
Go to Settings to activate Windows.

SCADA of MKB Enterprises (Pvt) Ltd Plant

MKB Enterprises (PVT) LTD

HMI Application



**Welcome to the HMI Application
of MKB Enterprises (PVT) LTD**

Click to open the HMI

SCADA of MCL Asphalt Plant

Mohmand Construction Limited Asphalt Plant

HMI Application



**Welcome to the HMI Application
of MCL Asphalt Plant**

Click to open the HMI

Main

About

SCADA of MCL Asphalt Plant

11/3/2025 7:25:58 PM

Mohmand Construction Limited Asphalt Plant

Batch No.

Reset

Main System Screen

Enter Total number of Batches

Exit

Aggregate Storage and Cold Feed System

Aggregate Dryer and Heating System

Dust Control and Collection System

Hot Aggregate Screening System

Hot Bin Storage and Batch Preparation System

Pugmill Mixing System

Heated Bitumen Spraying System

Truck Loading System

LOCAL MODE

STOP

Batch Formula

Manual Mode

Asphalt Mixing Time Sec

Mixing Time

ENTER

Degree C

Kg

Kg

Mixer Discharge

2 Bar

2 Bar

4 Bar

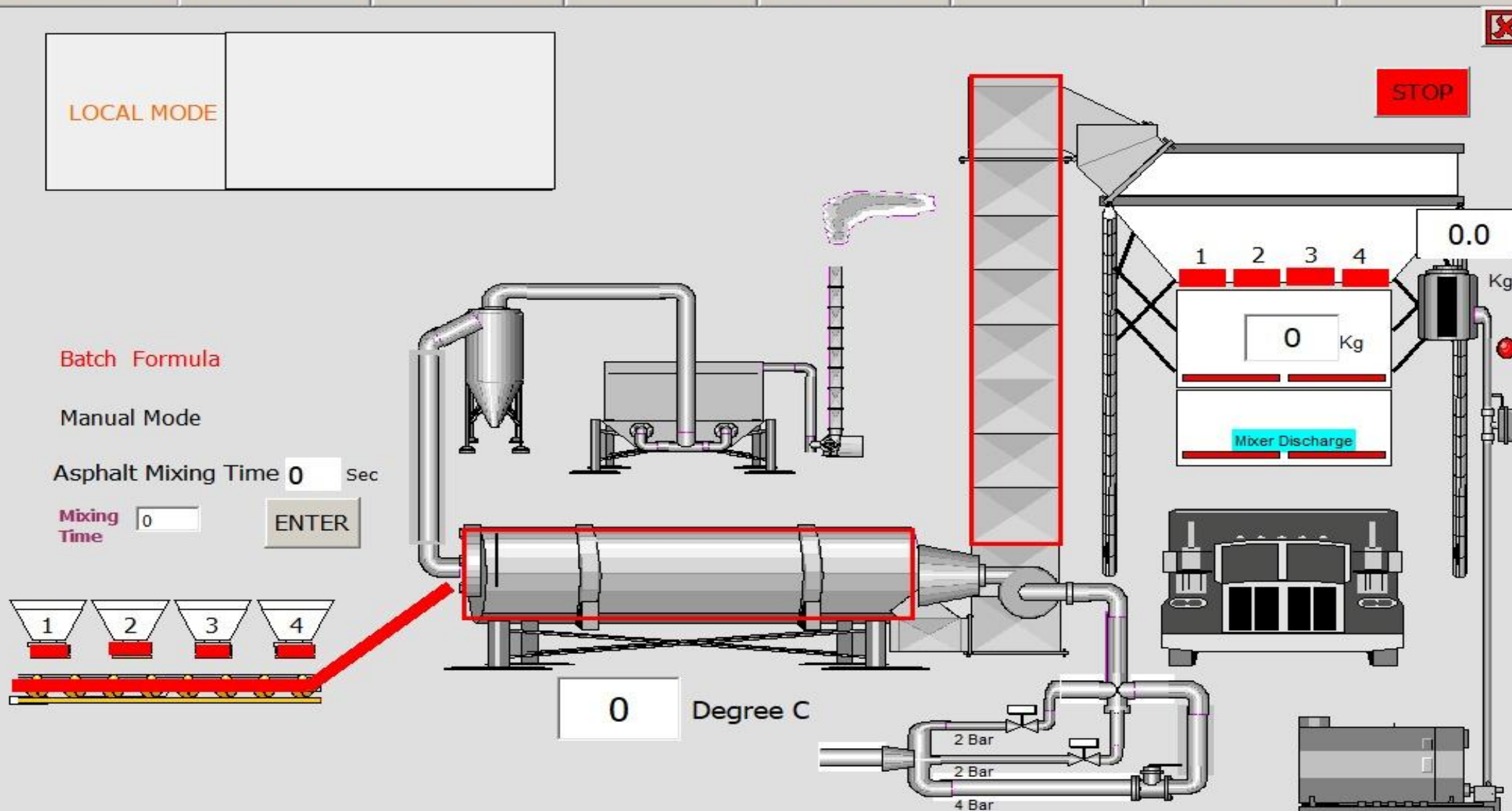

SCADA of MCL Asphalt Plant

Mohmand Construction Limited Asphalt Plant

Aggregate Dryer System - Alarm Screen

Main

System

Configuration

Alarm



Mixer Motor



Exhaust Motor



Burner Blower Motor



Dust Control and Collection System

Dust Control and Collection System

Aggregate Storage and Cold Feed System

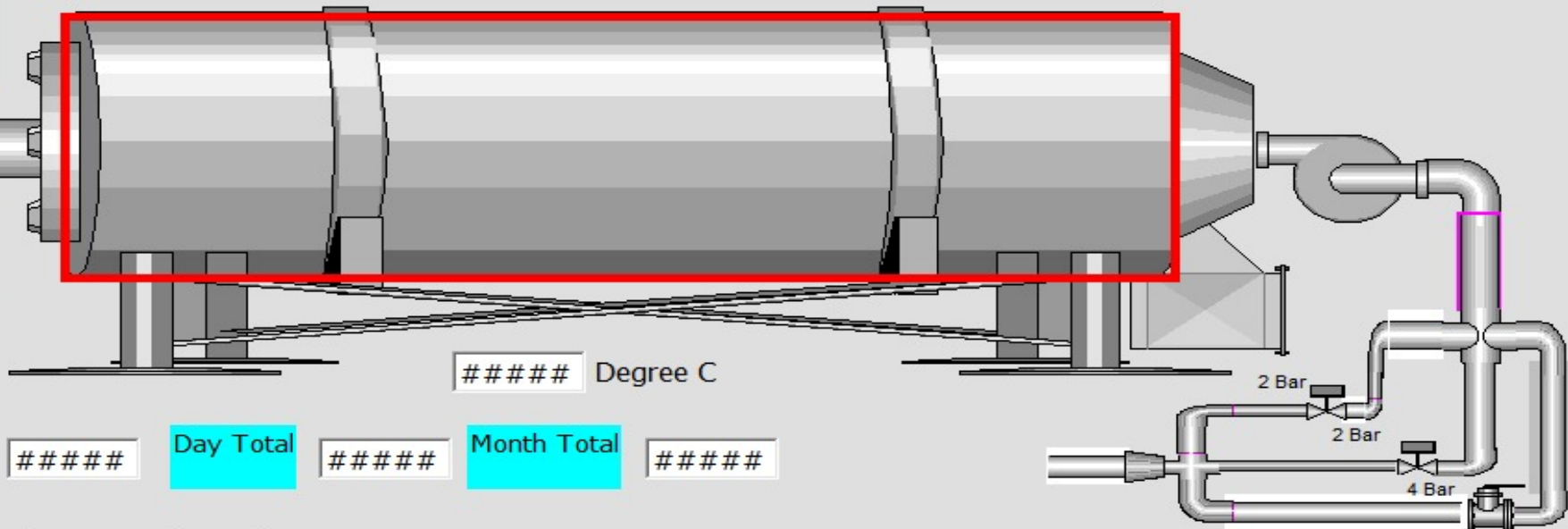

Dryer System Number Of Start

####

Day Total

####

Month Total

####

No.	Time	Date	Status	Text
-----	------	------	--------	------

GR

SCADA of MCL Asphalt Plant

Heated Bitumen Spraying System - System Screen

Main System Configuration Alarm



Weight Of Heated Bituman

0.0 Kg

Bituman Spray Motor



Bituman Valve



Pugmill Mixing System

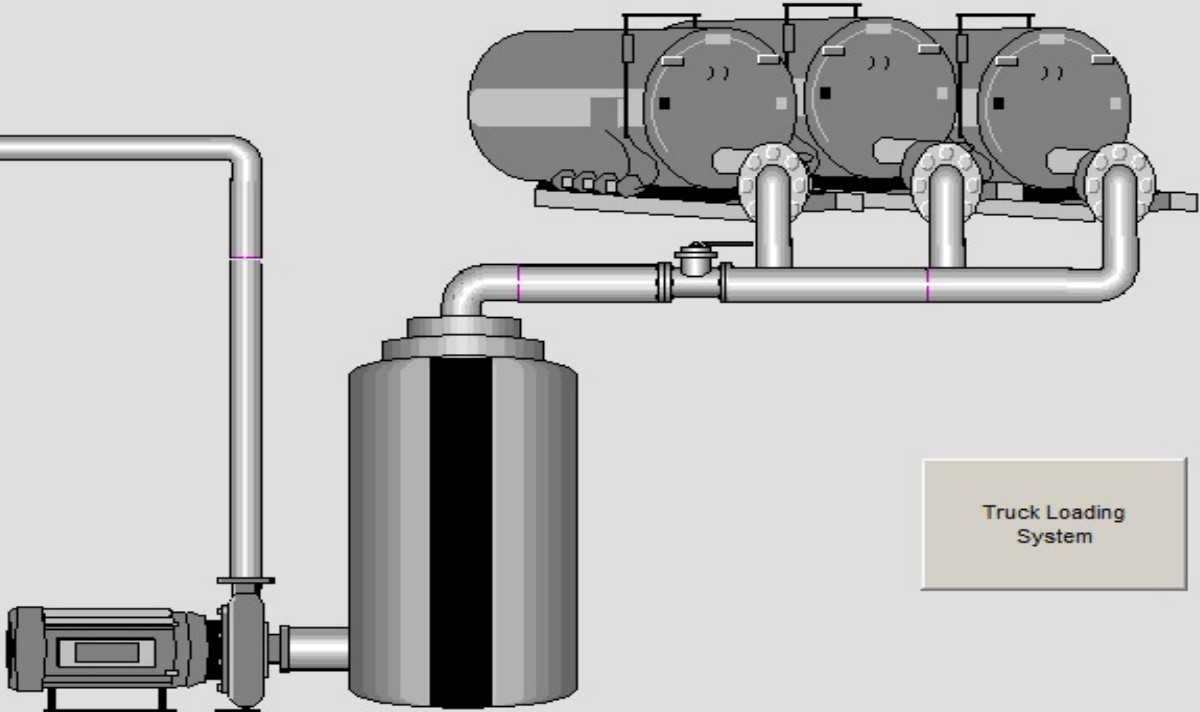
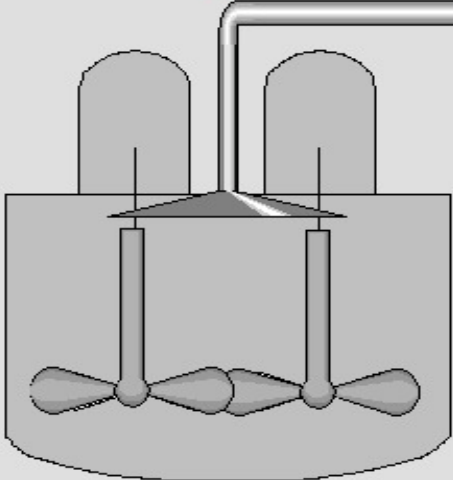

Truck Loading System

No.	Time	Date	Status	Text	GR
-----	------	------	--------	------	----

SCADA of MCL Asphalt Plant

Mohmand Construction Limited Asphalt Plant

11/3/2025 7:30:37 PM

Heated Bitumen Spraying System - Configuration Screen

Main

System

Configuration

Alarm



Analog Instrument	HIHI Setpoint	HI Setpoint	LO Setpoint	LOLO Setpoint	Current Value
Weight of heated Bitumen	#####	#####	#####	#####	0.00

Heated Bitumen Spray Motor in Pugmill

Not Running

AUTO MANUAL



0.00

Runtime Reset

Weight of Heated Bituman

Day Total Volume 0.00 Day Volume Reset

week Total Volume 0.00 Week Volume Reset

Month Total Volume 0.00 Month Volume Reset

SCADA of MCL Asphalt Plant



Relationship Between DT & SCADA

- From SCADA to Digital Twin

SCADA supervises, Digital Twin simulates — together they enable intelligent automation

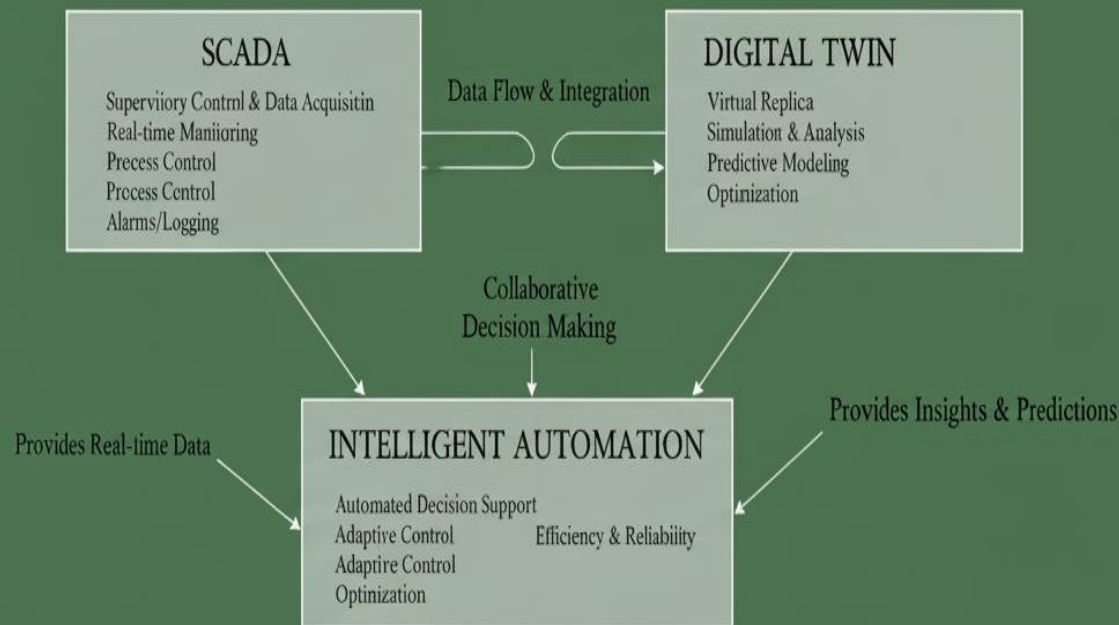

SCADA supervises, Digital Twin simulates — together they enable intelligent automation

DT In SCADA Systems



DT and SCADA: Data Flow Relationship

- SCADA collects data → DT analyzes, predicts, and feeds back optimized
- control parameters → SCADA executes actions.
- This section illustrates the seamless **data flow** from physical sensors to the Digital Twin, emphasizing how real-time data collection enables accurate representations of physical assets. Understanding this process is crucial for effective monitoring and decision-making in industrial automation.

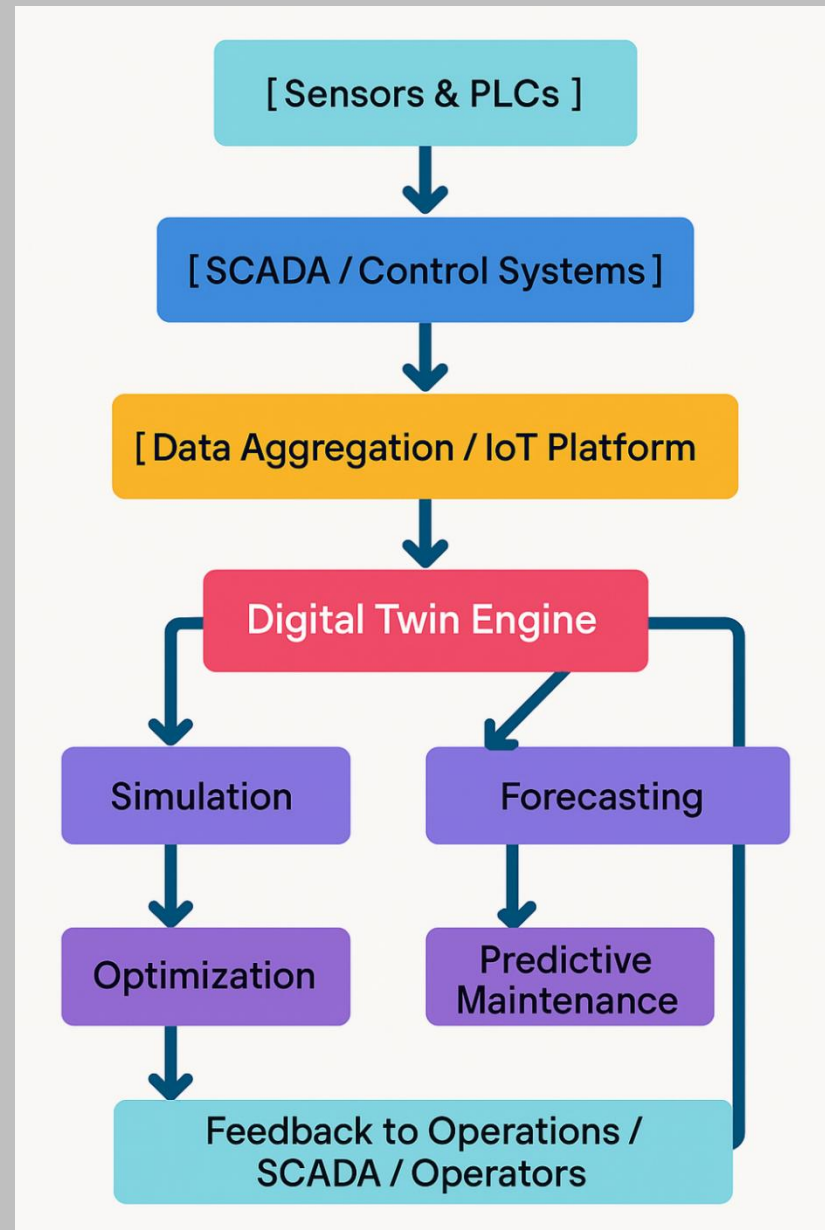

Integration Architecture

- A shared IoT and cloud platform connects SCADA systems with DT models through APIs and OPC-UA protocols.

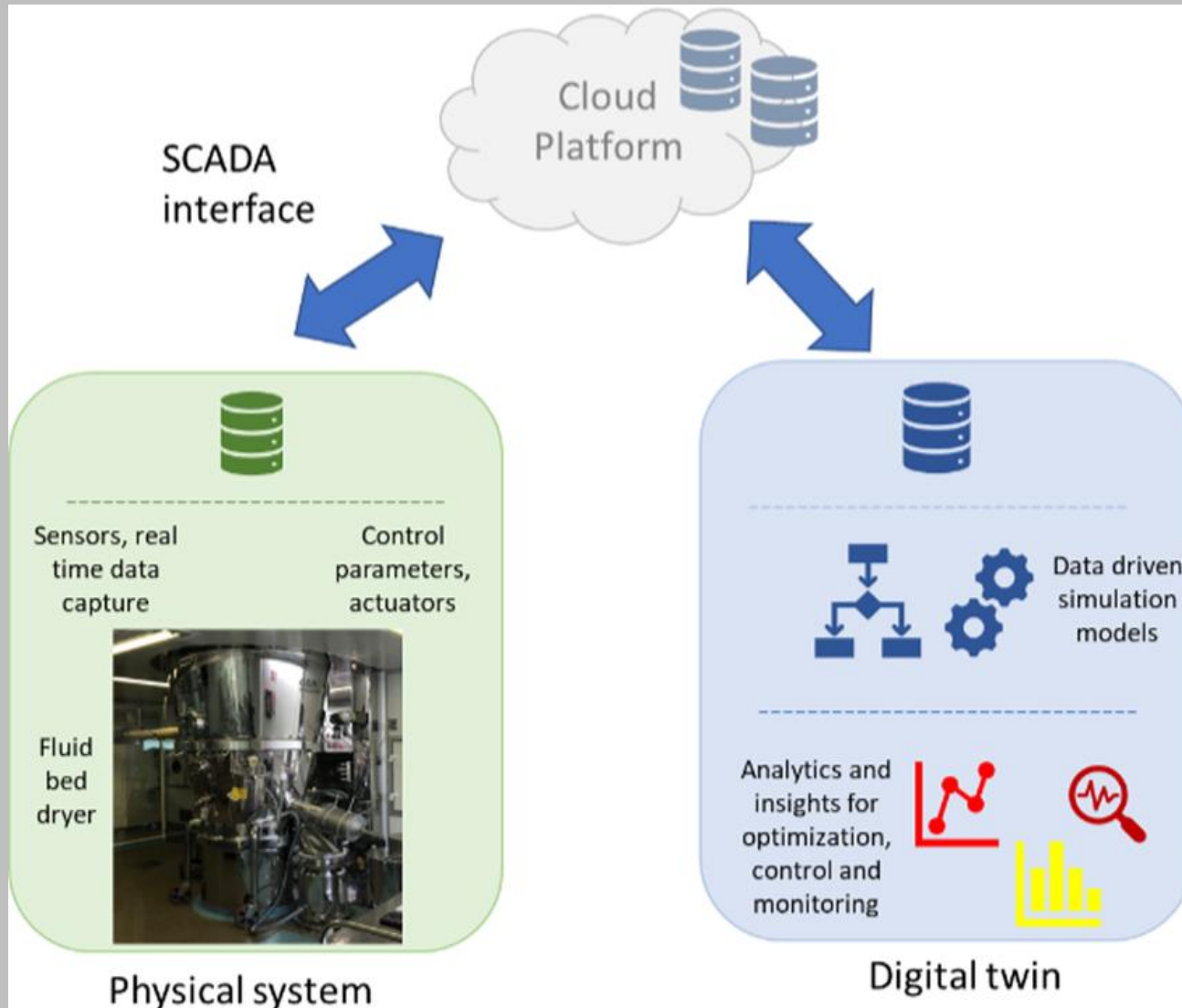

Example: Smart Manufacturing Line

- In a smart factory, SCADA controls real-time machine operations, while DT predicts failures and simulates production optimization.

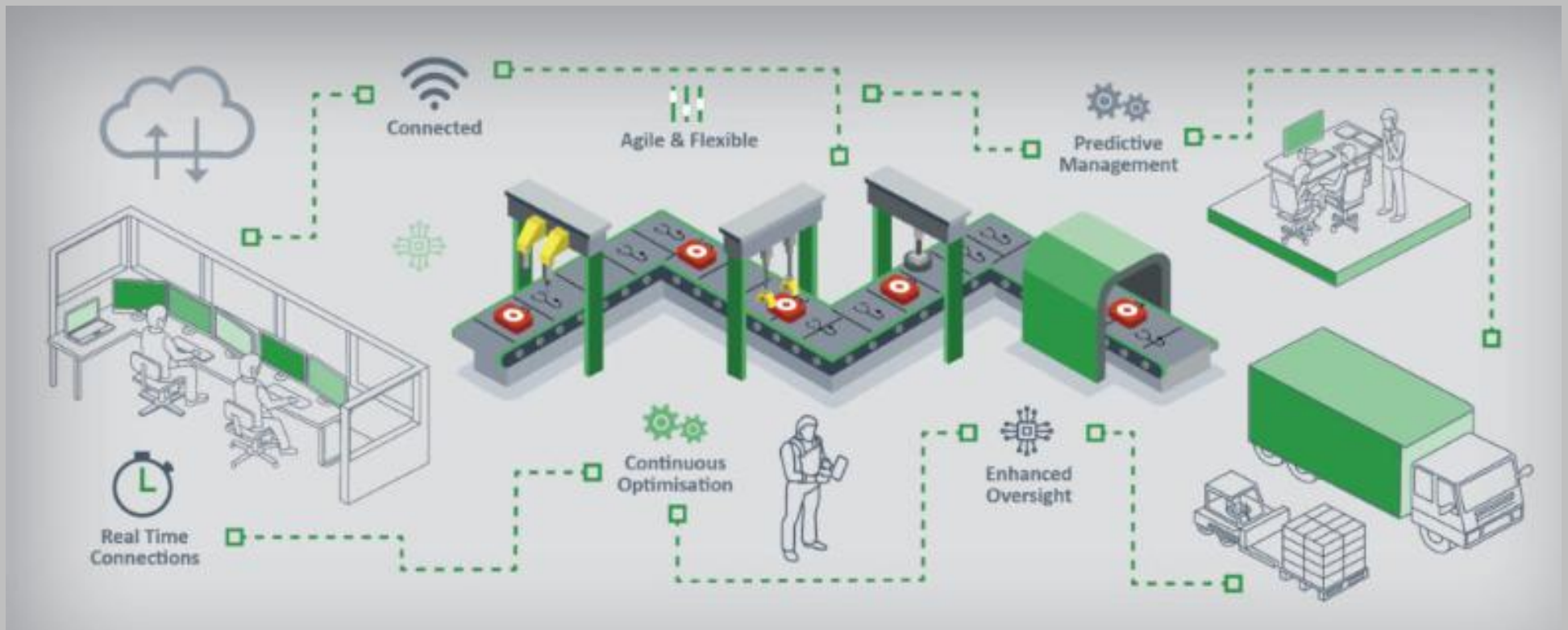

Energy Management

- DT uses SCADA data for turbine efficiency and fault detection in hydro and wind plants.



Smart Building Management

- DT simulates HVAC performance; SCADA ensures real-time operation — together reducing energy cost by up to 20%.

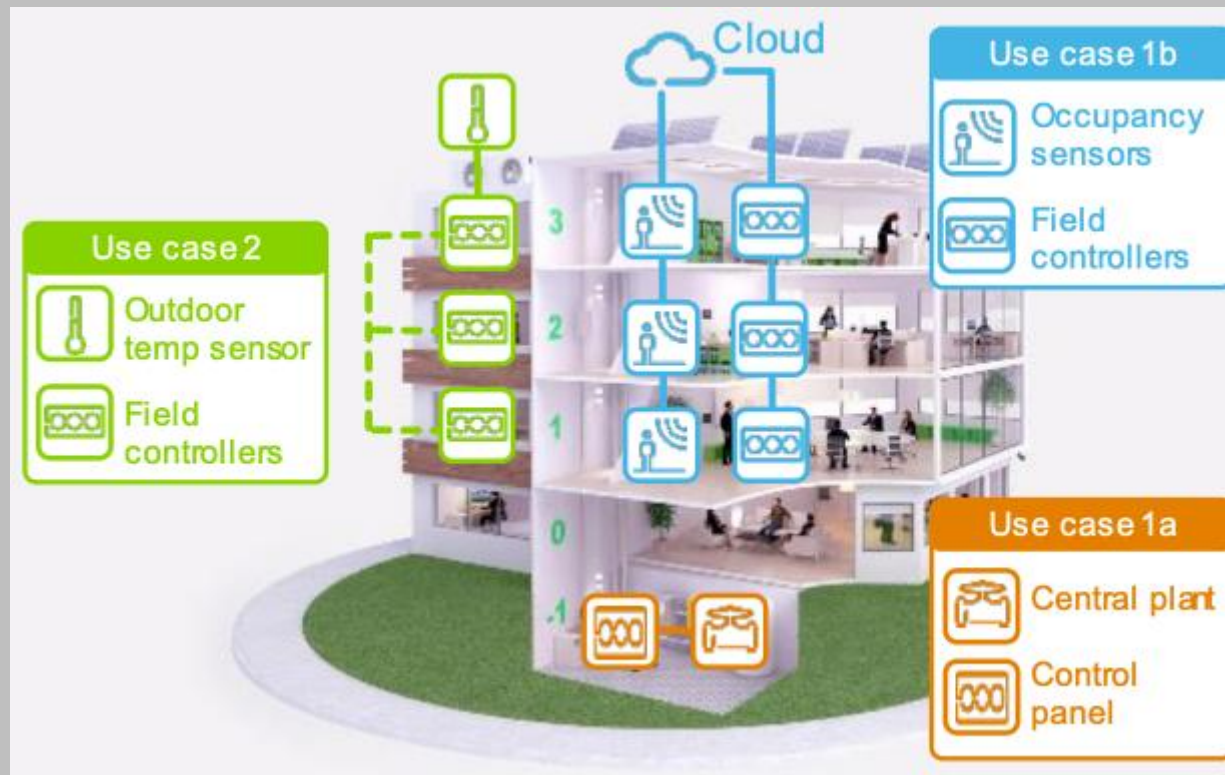

Advantages and Limitations

- Advantages

Enhance real-time monitoring and predictive analytics, improving operational efficiency across various industries

- Limitations

High implementation costs and data security concerns can hinder the widespread adoption of Digital Twin technology.

Conclusion

- Digital Twins elevate SCADA from monitoring to intelligent decision-making. Their synergy marks a step toward fully autonomous and optimized industrial ecosystems

Any Question

Or

Feedback

Thanks